



Please use your phone camera to scan the QR code to Visit DayOptics website or Follow us on LinkedIn

en.dayoptics.com | 

PRODUCT CATALOG

HO

Hunan Dayoptics, Inc.

Add: 008, Jinshui West Road, Ningxiang Jinzhou New District,
Changsha, 410600, Hunan, China

Tel: +86 731-8705 1588

BO

Fujian Dayoptics, Inc.

Add: Building 6, No. 66 Anxia Road, Nanyu Gaoqi Industrial Park,
Fuzhou High-tech Zone, Fuzhou, 350109, Fujian, China

Tel: +86 591-8321 5681



To Simplify and Beautify Optical Making

ABOUT DAYOPTICS

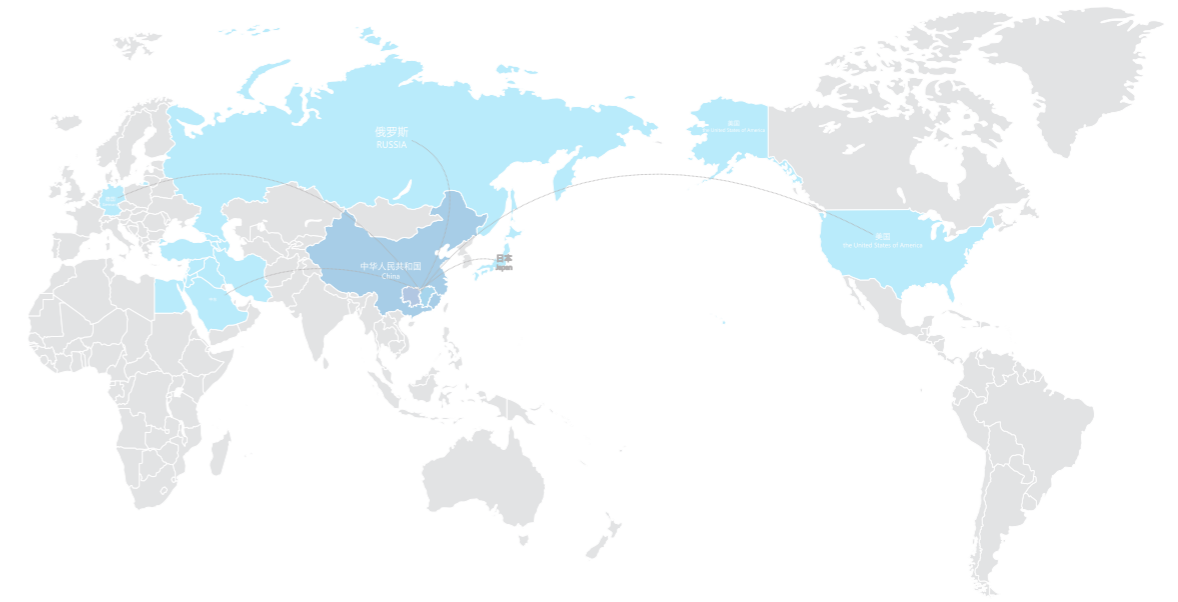

Founded in 2005, DayOptics has always focused on the R&D, manufacturing of photonics products. Our products cover precision optical components, optical assemblies, laser components, and optical systems, widely used in many fields such as lasers, optical communications, biomedicine, semiconductors, AI (artificial intelligence), IOT (Internet of Things), 5G, semiconductors, and defense. The products have been exported to USA, Japan, Russia, EU, ASEAN, the Middle East and other countries and regions.

With the spirit of "pursuing perfection and excellence in innovation", DayOptics breaks through key technologies, establishes precision manufacturing platforms, and provides one-stop optical solutions for domestic and foreign customers.



Founded in
2005



Delivered to
50+ countries



Cooperating
partners 10,000+

COMPANY STRENGTH

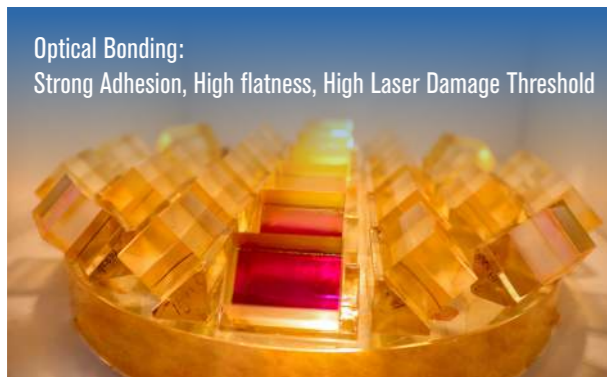
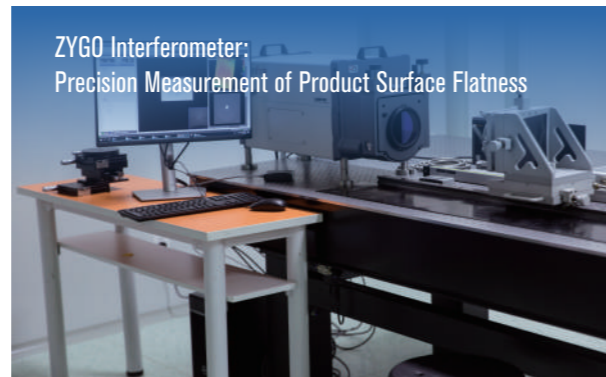
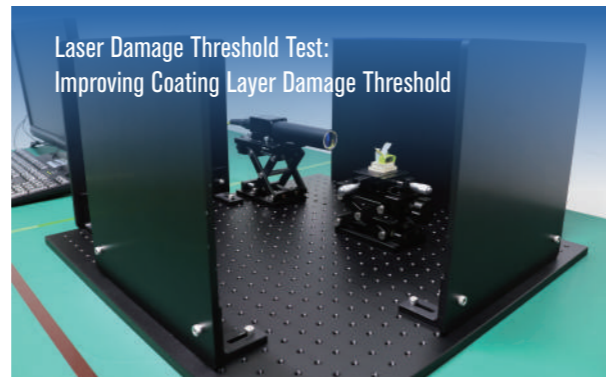

CONTENTS

Components Products

PBS 01

Polarizing Beam Splitter	01
High Power Polarization Beamsplitter	02
Polarization Cube Beamsplitter	05



MICRO-OPTICS ASSEMBLY 06



Waveplate 07

Waveplate Overview	07	High Power Waveplate	15
Low Order Waveplate	09	True Zero Order Waveplate	16
Zero Order Waveplate	10	Fresnel Rhomb Retarder	18
Achromatic Waveplate	12	Polarization Rotator	19
UV Achromatic Waveplate	13	Holder	20
IR Waveplate	14		



Polarizer 21

Polarizers Overview	21	Wollaston Polarizers	31
High Power Glan Laser Polarizer	23	Rochon Polarizers	33
Glan Taylor Polarizers	25	Glan Thompson polarizer	35
High Transmission Polarizer	27	Beamsplitter Cube	36
Glan Thompson Polarizers	29	Thin Film Polarizer	36
		Thin Film Polarizer-45°	37





ETALON 38



CONTENTS

LYOT DEPOLARIZER	39	
-------------------------	-----------	--

E-O Q Switch	41	
EO Q Switch BBO	41	
EO Q-Switches-KD*P	42	

WINDOW WEDGE	43	
	45	

FILTER	46	
---------------	-----------	--

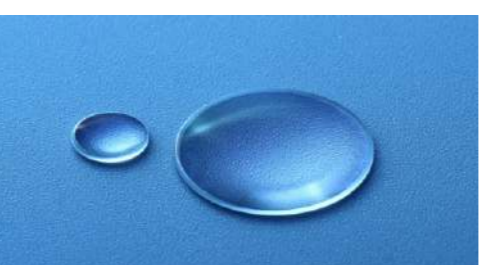
Lens	47		
Lens Overview	47		
Plano Convex Cylindrical Lens	49	Plano Concave Lens	54
Plano Concave Cylindrical Lens	50	Double Convex Lens	55
Cylindrical Positive Achromatic Lens	51	Double Concave Lens	56
Achromatic Lens	57	Ball Lens	58
C-Lens	52		
Plano Convex Lens	53		

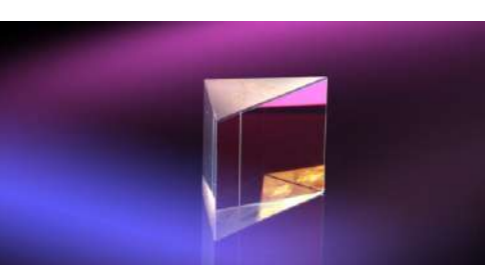
Prism	59		
Prism Overview	59	Right Angle Prisms & Anamorphic	62
Penta Prisms	60	Dove Prisms	63
Beamsplitter Penta Prisms & Corner Cube Retroreflectors	61	Roof Prisms & Rhombic Prisms	64

Coating	65	
Anti-Reflective Coating	65	
Dielectric Coating- HR Coating And PR Coating	67	
Polarization Beamsplitter Coating	69	
Mirror-Metal Coating	70	

Birefringent Crystal	71		
YVO ₄	71	MgF ₂	72
Calcite	71	Quartz	72
a-BBO	71		
LiNbO ₃	72		

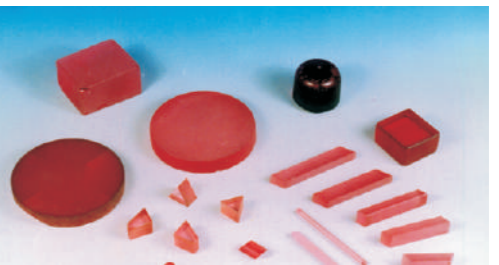
Laser Crystal	73	
Ti:Sapphire	73	
Nd:YAG	73	
Nd:YVO ₄	73	

NLO Crystal	75	
BBO	75	
KTP	75	
LBO	75	
LiNbO ₃	75	

Passive Crystal	77	
Terbium Gallium Garnet(TGG)	78	
Optical Crystal	79	

Optical Glass	80	
Color Glass	82	

NEW PRODUCTS



UV Achromatic Waveplate

See Page 13

UV Application
Wide wavelength Range

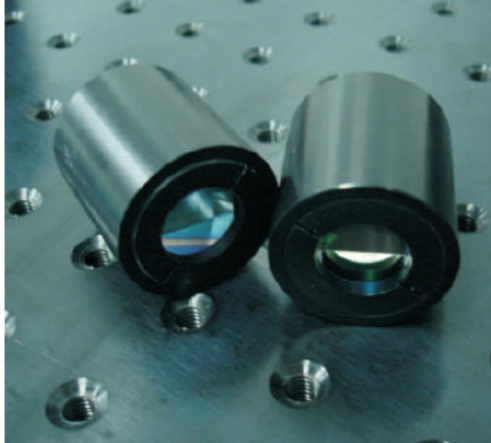

Glan-Thompson Polarizing Beamsplitter Cube

See Page 35

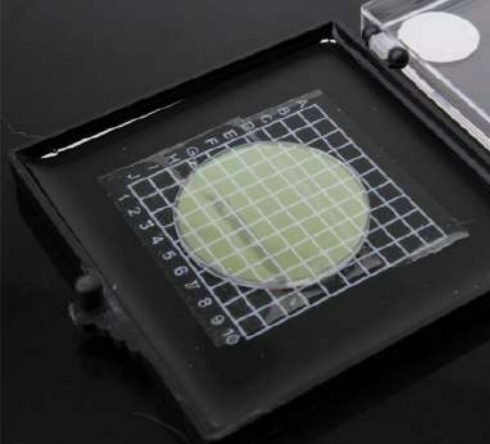

IR Waveplate

See Page 14

True Zero Order Waveplate
Better parallelism
High transmission

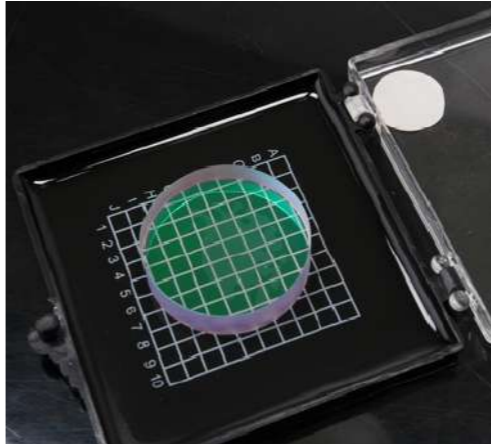

Thin Film Polarizer-45°

See Page 37

The single plate
cost-effective

POLARIZING BEAM SPLITTER

Polarizing Cube Beamsplitters split randomly polarized beams into two orthogonal, linearly, polarized components-S-polarized light is reflected at a 90deg. Angle while P-polarized light is transmitted. Each beamsplitter consists of a pair of precision high tolerance right angle prisms cemented together with a dielectric coating on the hypotenuse of one of prisms.

Currently, as coating technologies and assembly techniques have improved, so there are many types of polarizing beamsplitter cubes can be provided in the market. Dayoptics has own technology in providing two types of high precision polarizing beamsplitter cube. One is by using cemented method for PBS (as standard PBS), the other one is using optical bonding method for the interface of PBS (as high power PBS). The comparison specification of two PBS as following for your reference.

Dayoptics	Polarizing Beam Splitter (PBS)	
	Standard PBS	High Power PBS
Interface Surface	Cemented	Optically Bonded
Damaged Threshold @ 1064 nm,10ns	0.3J/cm2	>15 J/cm2
Beam Deviation	<3'	<3'
Flatness	L/4	L/8
Transmission @ 1064nm	TP>95%	TP>97%;TP>96%@355nm
Surface Quality	60/40 Scratch/Dig	40/20 (20/10) Scratch/Dig
Extinction Ratio	>500:1	>1000:1

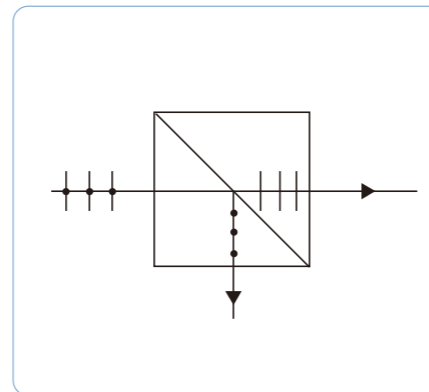

A primary advantage of a direct-bonding technique over optical contacting is that the increased strength of the bond allows processing after assembly, meaning that the bonded parts can be cut, shaped, polished or coated to create highly tolerated or multicomponent assemble without the temperature constraints or threat of delamination exhibited by other assembly techniques. Because there is no epoxy, the finished units are compact and thermally stable, exhibiting insignificant levels of absorption or scattering loss at the optical interface.

Flatness of PBS inspected by Interferometer

Parameter	Value	Units	QC
PV 99.90%	0.0963	waves	
RMS	0.0174	waves	
SAG	0.0082	fr	
IRR 99.90%	0.2265	fr	
4) Focus	-0.0013	waves	
5) X Astig	-0.0111	waves	
6) Y Astig	0.0045	waves	
7) X Coma	-0.0115	waves	
8) Y Coma	-0.0176	waves	
9) Spherical	-0.0105	waves	

ISO:3(0.0082(0.2265(0.0377)RMS=0.0392; RMSI=0.0392; RMSa=0.0377; fr(0.5461 um)

HIGH POWER POLARIZATION BEAMSPLITTER

High Power Damage Threshold Report from Quantel

LASER DAMAGE THRESHOLD

Customer: Dayoptics, Inc.
Purchase Order Number: P338
Substrate Material: BK-7 Glass
Part No.: PBS206-HP
PBS cube

Special Requirements: Per P.O.

Wavelength (nm): 1064
Repetition Freq. (Hz): 20
Pulse Width (FWHM, ns): 20
Axial Modes: Multiple
No. Sites Tested: 26
Damage Definition: Permanent surface change
Preparation: N2 Dustoff

Certificate No.: 13866 #1
Issued: Dec. 1, 2008
Coating Type: B/S@1064 nm
Lot No.: 136

Spot Diam. (FW/c2, mm): .5
Incidence Angle (deg.): Normal
Polarization State: Circular
Transverse Modes: TEM00
No. Shots/Site: 200
Inspection Method: Nomarski/Darkfield 150X

Fluence (J/cm2)	MW/cm2	%Fail
30.4	1214	100
21.7	867	33.3
17.3	694	10
15.2	607	0
13	520	0

Test Results: Damage Threshold: **15.2 J/cm2** or **607 MW/cm2**
Damage Type: Propagating pit(s) on the hypotenuse

"Big Sky Laser Technologies, Inc., certifies that the Laser Damage Threshold of this sample was tested as shown hereon. Fluence measurement precision was plus or minus 10%, traceable to NIST. The test method was substantially in agreement with ISO 11254. Specific calibration data are maintained in this office and are available on request. We certify that this test report conforms to all applicable provisions of the purchase order."

Jeff Runkel

HIGH POWER POLARIZATION BEAMSPLITTER

Dayoptics is dedicated to producing various High Power PBS. Compare to traditional PBS, it adopts special optical contacted technology which makes it has higher laser damage threshold.

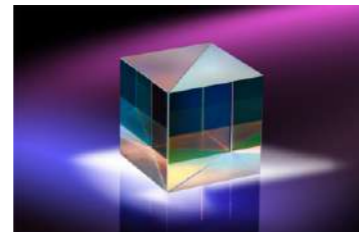

Features

- High Power High Damage Threshold: $\sim 15\text{J}/\text{cm}^2$ @ 1064nm 20ns, 20Hz (Certificate No. 13866#1)
- Green Optics. Epoxy-free! Optical Contacted.
- Transmission: $>97\%$ @Central Wavelength ($T_p >96\%$ @355nm)
- Extinction Ratio: Better than 30dB for 1064nm
- High Coating Performance
- Surface quality: 20/10 Scratch/Dig
- Wavelength Range (Other Material & Wavelength Available)
 - 1064nm $\pm 20\text{nm}$ (Material: BK7) 1550nm $\pm 25\text{nm}$ (Material: BK7)
 - 532nm $\pm 20\text{nm}$ (Material: BK7) 355nm $\pm 7\text{nm}$ (Material: Fused Silica)
- Design & Technical Support Services and Volume Production.

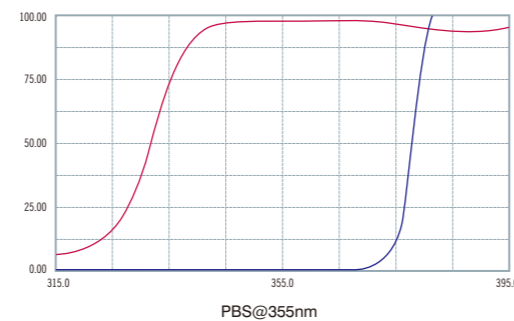
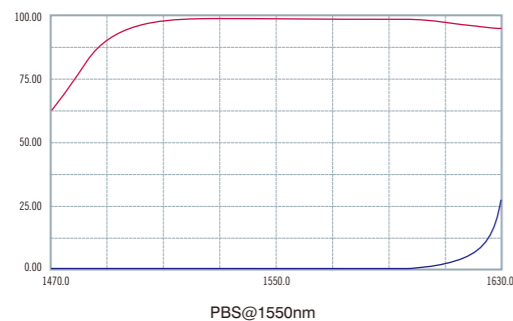
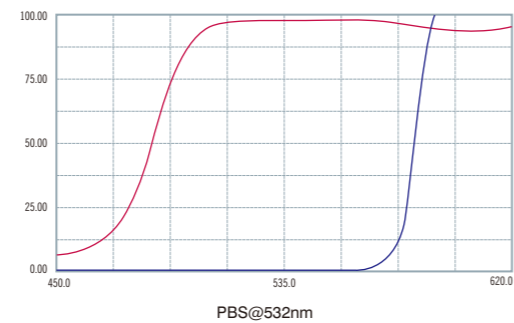
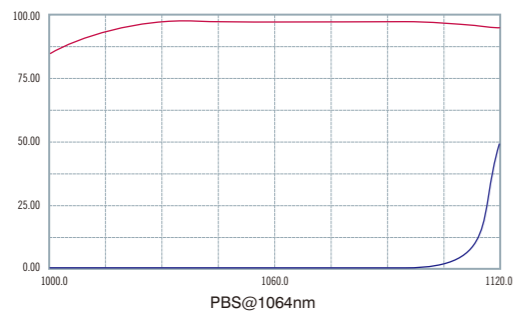

Single Wavelength

Part No.	Size Tolerance	Unit Price
PBS206-HP	6.35x6.35mm +/-0.1	\$58
PBS212-HP	12.7x12.7mm +/-0.2	\$128
PBS225-HP	25.4x25.4 mm +/-0.2	\$280

Order information: 1064nm PBS206-HP-1064nm

HIGH POWER POLARIZATION BEAMSPLITTER

Specifications

High Power High Damage Threshold	$> 3\text{-}5\text{J}/\text{cm}^2$ @ 1064nm 20ns, 20Hz
Green Optics	Epoxy-free! Optical Contacted
Extinction Ratio	$> 30\text{dB}$
Average	$T_{\text{avg}} > 92\%$
Wavelength Range	450-650nm、650-900nm、900-1200nm、1200-1600nm
Surface Quality	40/20 Scratch/Dig
Surface Figure	$< 1/4$ wave @633nm

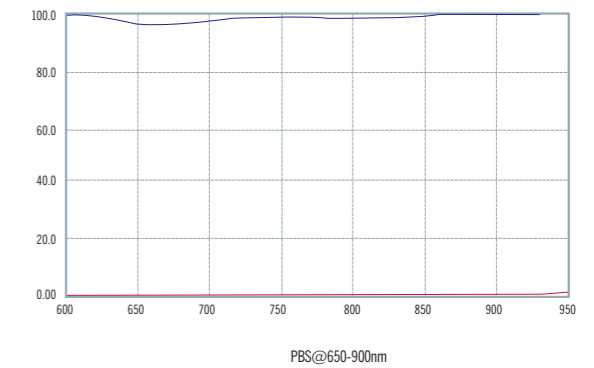
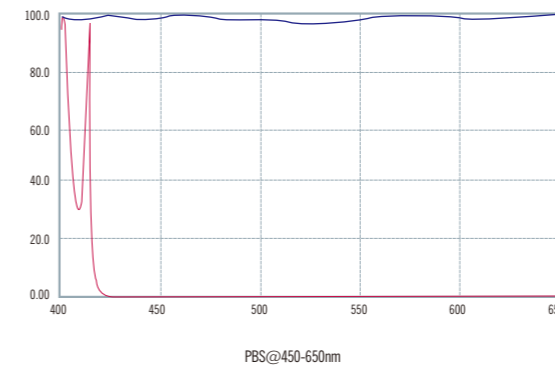

Broadband Wavelength

Part No.	Size Tolerance	Unit Price
PBS506-HP	6.35x6.35 mm +/-0.1	\$68
PBS512-HP	12.7x12.7 mm +/-0.2	\$148
PBS525-HP	25.4x25.4 mm +/-0.2	\$288

Order information: 450-650nm PBS506-HP-450-650nm

POLARIZATION CUBE BEAMSPLITTER

Polarizing Cube Beamsplitters split randomly polarized beams into two orthogonal, linearly, polarized components-S-polarized light is reflected at a 90deg. Angle while P-polarized light is transmitted. Each beamsplitter consists of a pair of precision high tolerance right angle prisms cemented by epoxy together with a dielectric coating on the hypotenuse of one of prisms.

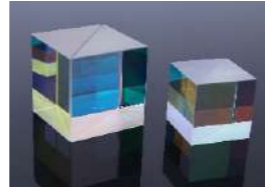

Single Wavelength PBS

Dimension Tolerance	± 0.2mm
Interface	By epoxy
Flatness	$\lambda / 4$ @ 632.8 nm per 25mm
Surface Quality	40/20 Scratch/Dig
Extinction Ratio	Tp:Ts > 500:1
Beam Deviation	< 3 arc minutes
Transmittance of P-Polarized Light	Tp > 95%
Clear Aperture	> 85%
Coatings	Polarization beamsplitter coating on hypotenuse face, AR-coatings (R < 0.25%) on all input and output face.
Standard Coating Wavelength	488, 532, 632.8, 808, 980, 1064, 1310, 1550 nm

Part No.	Size Tolerance	Unit Price
PBS206	6.35x6.35 mm +/-0.1	\$38
PBS212	12.7x12.7 mm +/-0.2	\$45
PBS225	25.4x25.4 mm +/-0.2	\$68

Order information: 1064nm PBS206-1064nm

Broadband PBS

Dimension Tolerance	± 0.2mm
Interface	By epoxy
Flatness	$\lambda / 4$ @ 632.8 nm per 25mm
Surface Quality	40/20 scratch/dig
Extinction Ratio	> 500:1
Beam Deviation	< 3 arc minutes
Transmittance of P-Polarized Light	> 92%
Clear Aperture	> 85%
Coatings	Polarization beamsplitter coating on hypotenuse face, AR-coatings (Ravg < 1%) on all input and output face.
Standard Coating Wavelength	450-650, 650-900, 900-1200, 1200-1600nm

Part No.	Size Tolerance	Unit Price
PBS506	6.35x6.35mm +/-0.1	\$45
PBS512	12.7x12.7mm +/-0.2	\$55
PBS525	25.4x25.4 mm +/-0.2	\$78

Order information: 450-650nm PBS506-450-650nm

MICRO-OPTICS ASSEMBLY

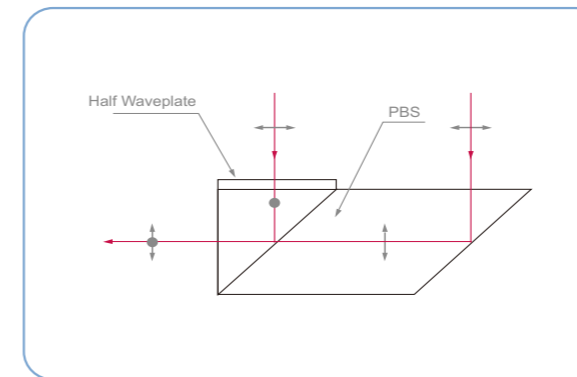

PBS + Waveplate

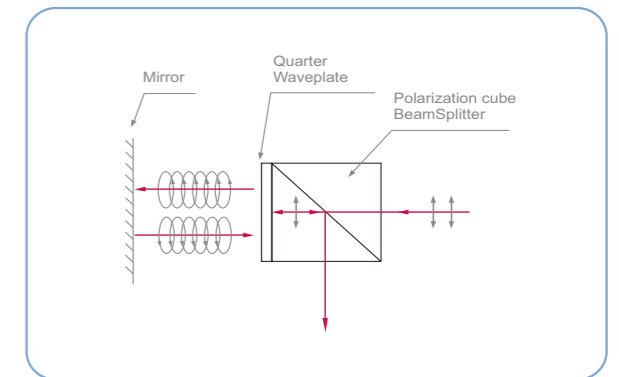

Isolators

Specifications

Material	BK7 + Quartz
Wavelength	1064 nm
Surface Flatness	$< \lambda / 4$ @ 633nm (or better)
Surface Quality	20/10 Scratch/Dig
Clear Aperture	> 85%
Beam Deviation	< 3'
Coating	PBS Coating, Tp > 96%, Ts < 0.1 @ AOI = 45°; AR Coating, R < 0.2% @ 1064nm
Damaged Threshold @ 1064nm, 10ns	> 15J/cm²

Standard Products

PBS+Waveplate		
Part No.	Dimension(mm)	Dimension Tolerance(mm)
OAPW635	6.35x6.35	+/-0.1mm
OAPW1000	10x10	+/-0.2mm
Isolators		
Part No.	Dimension(mm)	Dimension Tolerance(mm)
OAPW-I635	6.35x6.35	+/-0.1mm
OAPW-I1000	10x10	+/-0.2mm

Minimum Order Quantity: 5 pcs

Note: We can make the Micro-Optics Assembly according to your requirements

WAVEPLATE OVERVIEW

Waveplate	Part #	Illustration	Wavelength Bandwidth ($\lambda/4@532\text{nm}$)	($\lambda/100$ Bandwidth) $\lambda/2 @532\text{nm}$	Plates	Acceptance Angle	Typical Length	Damage Threshold	Page
Multi-order Waveplate(Quartz) (Can be Replaced by Low-order)	WPMxxxx			0.29nm ($T=0.9686\text{mm}$)	Single	Low	1~2mm	1GW/cm ²	
Low-order Waveplate(Quartz)	WPLxxxx			0.92nm ($T=0.3036\text{mm}$)	Single	Medium	0.2~0.5mm	1GW/cm ²	9
Zero-order Waveplate (Quartz)	Optically Contracted WPOxxxx			19.22nm ($\Delta T=0.0145\text{mm}$)	Double (Optical Contacted)	Low	~1mm	~200 MW/cm ²	10
	Air-spaced WPAxxxx			19.22nm ($\Delta T=0.0145\text{mm}$)	Double (Air Spaced)	Low	~1mm	~500 MW/cm ²	11
	Cemented WPCxxxx			19.22nm ($\Delta T=0.0145\text{mm}$)	Double Cemented (Epoxy)	Low	~1mm	~10MW/cm ²	11
Achromatic Waveplate (Quartz)	WPBxxxx			200 nm	Double (Optical Contacted or Air Spaced)	Low	~2mm	~10MW/cm ²	12-13
IR Waveplate	WPSXXX-M			19.22nm ($T=0.022\text{mm}$)	Single	High	<0.2mm	>1GW/cm ²	14

Waveplate

WAVEPLATE OVERVIEW

Waveplate	Part #	Illustration	Wavelength Bandwidth ($\lambda/4@532\text{nm}$)	($\lambda/100$ Bandwidth) $\lambda/2 @532\text{nm}$	Plates	Acceptance Angle	Typical Length	Damage Threshold	Page
True Zero-order Waveplate	High Power Waveplate (Quartz, BK7, Fused Silica) WPH xxxx			19.22nm ($T=0.0145\text{mm}$)	Double (Optical Bonding)	High	~1mm	>1GW/cm ²	15
	Cemented (Quartz, BK7, Fused Silica) WPF xxxx			19.22nm ($T=0.0145\text{mm}$)	Double (Cemented by Epoxy)	High	~1mm	~10MW/cm ²	16
	Single Plate (Quartz) WPS xxxx			19.22nm ($T=0.0145\text{mm}$)	Single	High	<0.2mm	>1GW/cm ²	16
	Single Plate (Quartz) with BK7 Holder WPK xxxx			19.22nm ($T=0.0145\text{mm}$)	Single (BK7 Ring as Holder)	High	<0.2mm	>1GW/cm ²	17
Double Wavelength Waveplate (Quartz)	WPDxxxx			Very Small	Single	Low	0.2~2mm	1GW/cm ²	17
Fresnel Rhomb Retarder (Fused Silica, BK7, CaF ₂)	FRBxxxx			Broadband	Single or Double (Optical Contact or Cemented)	Medium		500 MW/cm ²	18
Polarization Rotators (Quartz)	WPRxxxx			20 nm	Single	High	3.33mm (90° @ 532nm)	1GW/cm ²	19

Waveplate

LOW ORDER WAVEPLATE

The low order waveplate which can be replaced by multi-order waveplate is designed to give a retardance of several full waves, plus the desired fraction. This results in a single, physically robust component with desired performance. However, even small variation in wavelength or temperature will result in significant changes in the desired fractional retardance.



Specifications

Material	Quartz
Dimension Tolerance	+0.0, -0.1
Wavefront Distortion	$\lambda / 8 @ 633\text{nm}$
Retardation Tolerance	$\lambda / 60 - \lambda / 150$ ($\lambda < 400\text{nm}$); $\lambda / 150 - \lambda / 360$ ($400 < \lambda < 700\text{nm}$); $\lambda / 350 - \lambda / 600$ ($\lambda > 700\text{nm}$);
Parallelism	< 1 arc second
Surface Quality	20/10 Scratch/Dig
Clear Aperture	Central 90%
AR Coating	< 0.2% @ wavelength
Holder	Refer to «Holders for waveplates»

Standard Wavelength: 266nm, 355nm, 532nm, 632.8nm, 780nm, 808nm, 980nm, 1064nm, 1310nm, 1550nm

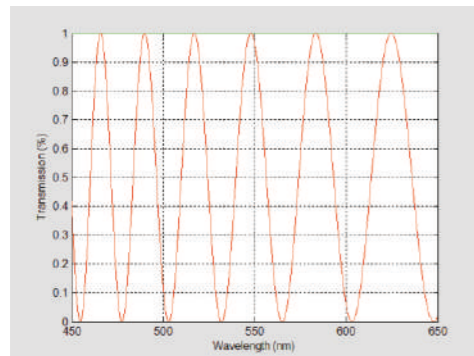

$\lambda / 2 @ 532\text{nm}$

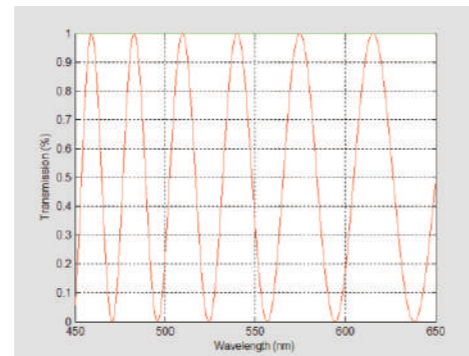

$\lambda / 4 @ 532\text{nm}$

Dayoptics Standard Products (Without Holder)

Quarter Waveplates P/N#	Half Waveplates P/N#	Diameter(mm)	Unit Price
WPL210Q	WPL210H	10.0	\$45
WPL212Q	WPL212H	12.7	\$52
WPL215Q	WPL215H	15.0	\$65
WPL220Q	WPL220H	20.0	\$75
WPL225Q	WPL225H	25.4	\$85
WPL230Q	WPL230H	30.0	\$95

ZERO ORDER WAVEPLATE

The zero order waveplate is designed to give a retardance of zero full waves, plus the desired fraction. Zero order waveplate shows better performance than multiple order waveplates. It has broad bandwidth and a lower sensitivity to temperature and wavelength changes. It should be considered for more critical applications.

Specifications

Material	Quartz
Dimension Tolerance	+0.0, -0.1
Wavefront Distortion	< $\lambda / 8 @ 633\text{nm}$
Retardation Tolerance	$\lambda / 500$
Parallelism	< 1 arc second
Surface Quality	20/10 Scratch/Dig
Clear Aperture	Central 90%
AR Coating	< 0.2% @ Wavelength
Holder	Refer to «Holder for Waveplate»

Standard Wavelength: 266nm, 355nm, 532nm, 632.8nm, 780nm, 808nm, 980nm, 1064nm, 1310nm, 1550nm

Note: wavelengths within the range of 240-2300nm are also available upon request.

Zero Order Waveplate Optically Contacted

- Optically Contacted
- AR Coated, R < 0.2%
- High Damage Threshold
- Better Temperature Bandwidth
- Wide Wavelength Bandwidth

Standard Wavelength: 266nm, 355nm, 532nm, 632.8nm, 780nm, 808nm, 850nm, 980nm, 1064nm, 1310nm, 1480nm, 1550nm

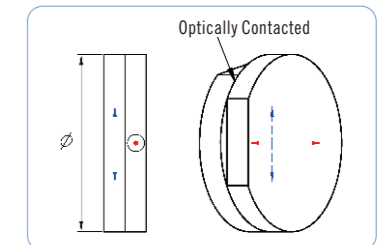

Dayoptics Standard Products (Without Holder)

Quarter Waveplates P/N#	Half Waveplates P/N#	Diameter(mm)	Unit Price
WPO210Q	WPO210H	10.0	\$75
WPO212Q	WPO212H	12.7	\$82
WPO215Q	WPO215H	15.0	\$88
WPO220Q	WPO220H	20.0	\$92
WPO225Q	WPO225H	25.4	\$108
WPO230Q	WPO230H	30.0	\$128

ZERO ORDER WAVEPLATE

Zero Order Waveplates Air-spaced

- Double Retardation Plates
- AR Coated, $R < 0.2\%$ and Mounted
- High Damage Threshold
- Better Temperature Bandwidth
- Wide Wavelength Bandwidth

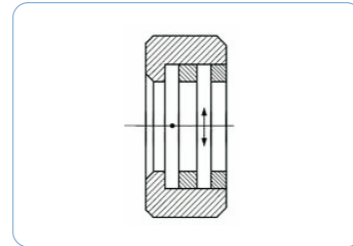

Dayoptics Standard Products

Quarter Waveplates P/N#	Half Waveplates P/N#	Waveplate Aperture(mm)	Mount Diameter(mm)	Mount Thickness (mm)	Unit Price
WPA210Q	WPA210H	10.0	25.4	6.0	\$85
WPA212Q	WPA212H	12.7	25.4	6.0	\$92
WPA215Q	WPA215H	15.0	25.4	6.0	\$98
WPA220Q	WPA220H	20.0	30.0	6.0	\$108
WPA225Q	WPA225H	25.4	30.0	6.0	\$118
WPA230Q	WPA230H	30.0	38.1	6.0	\$138

Zero Order Waveplates Cemented by Epoxy

This type of zero order waveplate is constructed of two multiple order waveplate with their axes crossed. Thus, the effect of the first plate is canceled by the second, except for the residual difference between them.

- Cemented by Epoxy
- Better Temperature Bandwidth
- Wide Wavelength Bandwidth
- AR Coated, $R < 0.2\%$

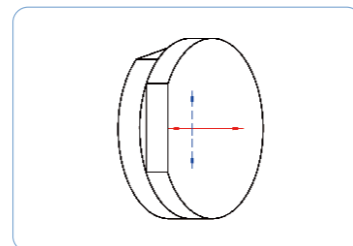

Dayoptics Standard Products (Without Holder)

Quarter Waveplates P/N#	Half Waveplates P/N#	Diameter(mm)	Unit Price
WPC210Q	WPC210H	10.0	\$72
WPC212Q	WPC212H	12.7	\$80
WPC215Q	WPC215H	15.0	\$86
WPC220Q	WPC220H	20.0	\$90
WPC225Q	WPC225H	25.4	\$106
WPC230Q	WPC230H	30.0	\$126

ACHROMATIC WAVEPLATE

Dayoptics has special designed achromatic waveplates by using two pieces of plate. It is similar to Zero-order waveplate except that the two plates are made from different materials, such as crystal quartz and magnesium fluoride. Since the dispersion of the birefringence can be different for the two materials, it is possible to specify the retardation values at a wavelength range. From the curve, you can see that the bandwidth of such achromatic waveplate is very wide, while the achromatic waveplates remain a nearly constant retardance over a range of wavelength.

Specifications

Material	Quartz and MgF_2
Wavefront Distortion	$\lambda / 8 @ 633nm$
Dimension Tolerance	+0.0, -0.1
Retardation Tolerance	$\lambda / 100$
Parallelism	<1 arc second
Surface Quality	40/20 Scratch/Dig
Clear Aperture	Central 90%
AR Coating	Ravg < 0.8% at Central Wavelength
Standard Wavelength	VIS 465-650nm, NIR 650-1100nm, IR 1000-1750nm

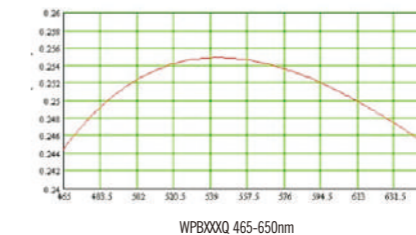
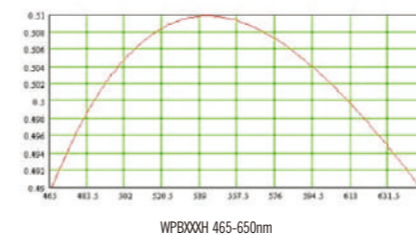
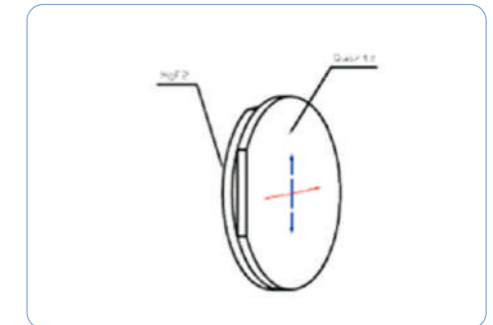

Achromatic Waveplate Optical Cemented

Quarter Waveplates P/N#	Half Waveplates P/N#	Diameter(mm)	Unit Price
WPB210Q	WPB210H	10.0	\$148
WPB212Q	WPB212H	12.7	\$158
WPB215Q	WPB215H	15.0	\$168
WPB220Q	WPB220H	20.0	\$208
WPB225Q	WPB225H	25.4	\$238
WPB230Q	WPB230H	30.0	\$278

Achromatic Waveplate Air-Spaced (Mounted)

Quarter Waveplates P/N#	Half Waveplates P/N#	Waveplate Aperture(mm)	Mount Diameter(mm)	Unit Price
WPB510Q	WPB510H	10.0	12.7	\$188
WPB512Q	WPB512H	12.7	25.4	\$198
WPB515Q	WPB515H	15.0	25.4	\$228
WPB520Q	WPB520H	20.0	25.4	\$268
WPB525Q	WPB525H	25.4	30.0	\$308
WPB530Q	WPB530H	30.0	38.1	\$358

UV ACHROMATIC WAVEPLATE

Dayoptics has special designed UV achromatic waveplates by using four pieces of plates. It consists of our product WPO and WPH. It has a small bandwidth and you can use that in the range of UV wavelength.

Specification

Material	Quartz and MgF ₂
Wavefront Distortion	$\lambda/4@633\text{nm}$
Dimension Tolerance	+0.0,-0.2
Retardation Tolerance	$\lambda/90$
Parallelism	<1 arc second
Surface Quality	40/20 Scratch/Dig
Clear Aperture	Central 85%
AR Coating	Ravg < 2.5% at Central Wavelength
Standard Wavelength	UV230-280nm ; UV280-350nm; UV350-450nm

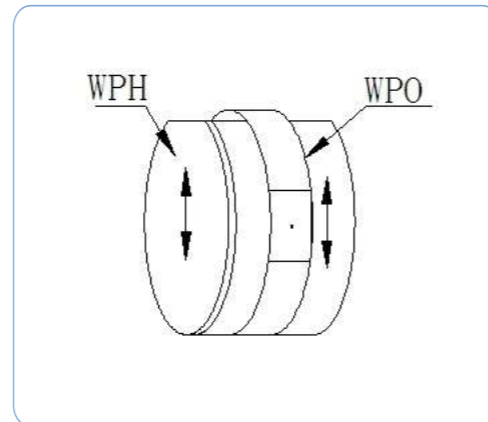

Achromatic Waveplate Optical Cemented

Quarter Waveplate P/N#	Half Waveplate P/N#	Diameter(mm)
WPB110Q	WPB110H	10.0
WPB112Q	WPB112H	12.7
WPB115Q	WPB115H	15.0
WPB120Q	WPB120H	20.0

IR WAVEPLATE

Specifications

Dimension	+0.0,-0.2mm
Clear Aperture	>90%
Wavefront Distortion	$\lambda/8@633\text{nm}$
Surface Quality	40/20 Scratch/Dig
Retardation Tolerance	$\lambda/300$
Parallelism	<1"
Coating	R < 0.5% @ central wavelength

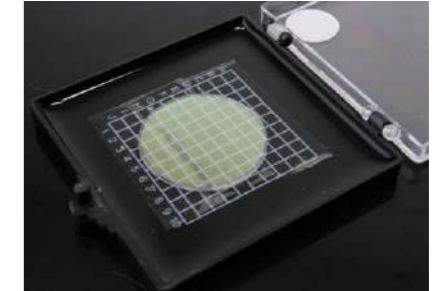

Standard Wavelength:

$\lambda/2$: 3500nm, 4000nm, 4500nm, 5000nm, 5500nm, 6000nm, 6500nm, 7000nm
 $\lambda/4$: 3500nm, 4000nm, 4500nm, 5000nm, 5500nm, 6000nm, 6500nm, 7000nm

Dayoptics Standard Products(Without Holder)

Quarter Waveplates P/N#	Half Waveplates P/N#	Diameter (mm)
WPS212Q-M	WPS212H-M	12.7
WPS220Q-M	WPS220H-M	20.0
WPS225Q-M	WPS225H-M	25.4

PS: as regards the true zero order quarter waveplate, if the thickness is too thin, we will do the one-order waveplate. More detail information, please send the mail to us: sales@dayoptics.com

HIGH POWER WAVEPLATE

Features

- True Zero Order Waveplate
- Epoxy Free
- High Power: > 10J/cm²@1064nm,20ns,20Hz
- Used Wavelength:400~3000nm
- Good for UV Application
- Easy Handling

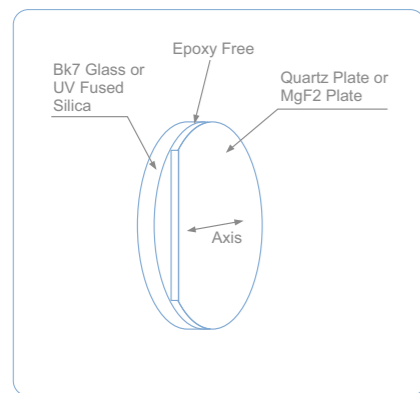

Waveplate Comparison	High Power Waveplate	Low-order Waveplate	Zero-order Waveplate (Cemented/Optical Contacted)
For Short	WPH	WPL	WPC / WPO
$\lambda / 100$ Spectra Bandwidth@532nm	9.16nm	0.51nm	9.16nm
$\lambda / 100$ Temperature Bandwidth ΔT	230.56K	12.13K	230.56K
Acceptance Angle	11.37°	2.63°	11.37°
Damage Threshold@1064nm, 10ns,20HZ	>10J/cm ²	>10J/cm ²	~0.1J/cm ² (WPC) ~2J/cm ² (WPO)
Extinction Ratio	High	High	Low

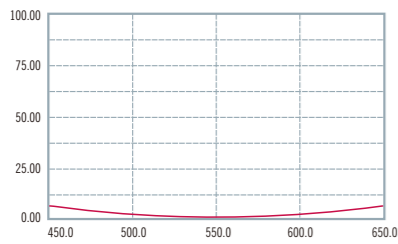

High Power Waveplate

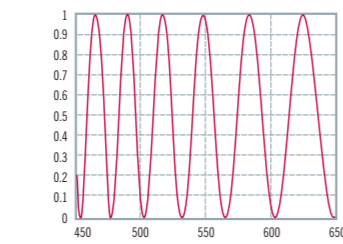

Low-order Waveplate

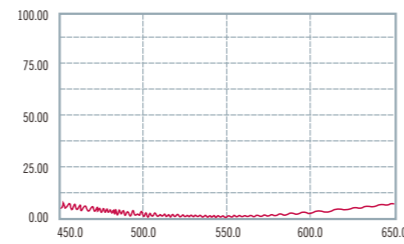

Zero-order Waveplate

Quarter Waveplate Part No.	Half waveplate Part No.	Diameter	Unit Price
WPH210Q	WPH210H	10.0	\$86
WPH212Q	WPH212H	12.7	\$95
WPH215Q	WPH215H	15.0	\$102
WPH220Q	WPH220H	20.0	\$115
WPH225Q	WPH225H	25.4	\$128
WPH230Q	WPH230H	30.0	\$158

Advantages of High Power Waveplate

- Compare with WPL, WPH has wider spectra & temperature bandwidth and wider angular field.
- Based on our unique optical bonding technology, WPH has higher damage threshold and better extinction ratio which compared with WPO or WPC.
- The thickness of WPH is more suitable for handling compare with single plate true zero order waveplate, which is easy to be damaged.

TRUE ZERO ORDER WAVEPLATE

This type of waveplate is constructed of a true zero order waveplate and a BK7 substrate. As the waveplate is very thin and easy to be damaged, the BK7 plates function is to strengthen the waveplate.

- Cemented by Epoxy
- Wide Angle Acceptance
- Better Temperature Bandwidth
- Wide Wavelength Bandwidth
- AR Coated, R<0.2%

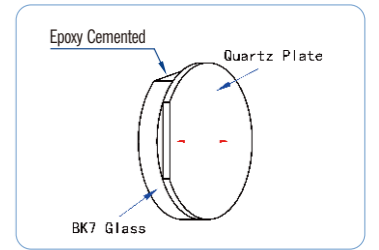

Standard Wavelength:

$\lambda / 4$: 532nm, 632.8nm, 780nm, 808nm, 980nm, 1064nm, 1310nm, 1480nm, 1550nm

$\lambda / 2$: 532nm, 632.8nm, 780nm, 808nm, 980nm, 1064nm, 1310nm, 1480nm, 1550nm

Dayoptics Standard Products

Quarter Waveplates P/N#	Half Waveplates P/N#	Diameter(mm)	Unit Price
WPF210Q	WPF210H	10.0	\$82
WPF212Q	WPF212H	12.7	\$90
WPF215Q	WPF215H	15.0	\$98
WPF220Q	WPF220H	20.0	\$110
WPF225Q	WPF225H	25.4	\$120
WPF230Q	WPF230H	30.0	\$150

True Zero Order waveplate Single Waveplate

This type of waveplate is made of a very thin quartz waveplate which function as true zero order. In some cases, the thickness required for single true zero order waveplates is too thin, they have to be provided as first order waveplate.

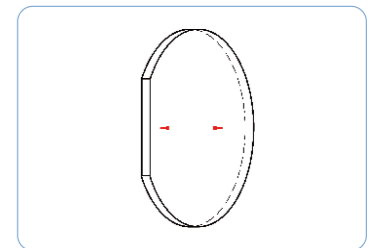

Standard Wavelength:

$\lambda / 4$: 1310nm, 1480nm, 1550nm

$\lambda / 2$: 980nm, 1064nm, 1310nm, 1480nm, 1550nm

Minimal Thickness: 0.038mm

Dayoptics Standard Products

Quarter Waveplates P/N#	Half Waveplates P/N#	Diameter(mm)	Unit Price
WPS210Q	WPS210H	10.0	\$68
WPS212Q	WPS212H	12.7	\$72
WPS215Q	WPS215H	15.0	\$75
WPS220Q	WPS220H	20.0	\$85
WPS225Q	WPS225H	25.4	\$95
WPS230Q	WPS230H	30.0	\$105

TRUE ZERO ORDER WAVEPLATE

WPQ is our new product, true zero order waveplate single waveplate on annual glass frames, the ray only through the quartz, epoxy free. It can meet high damage threshold and better parallelism. The frames can be designed by different requirement.

Standard Wavelength:
 $\lambda / 4$: 1310nm, 1480nm, 1550nm
 $\lambda / 2$: 980nm, 1064nm, 1310nm, 1480nm, 1550nm

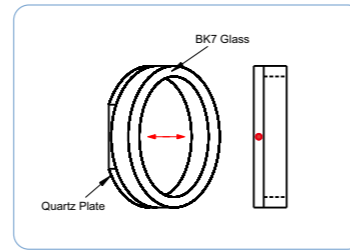

Dayoptics Standard Products

Quarter Waveplates P/N#	Half Waveplates P/N#	Diameter(mm)	Unit Price
WPQ210Q	WPQ210H	10.0	\$108
WPQ212Q	WPQ212H	12.7	\$118
WPQ215Q	WPQ215H	15.0	\$148
WPQ220Q	WPQ220H	20.0	\$168
WPQ225Q	WPQ225H	25.4	\$188
WPQ230Q	WPQ230H	30.0	\$208

Double Wavelength Waveplate

Double Wavelength Waveplate is a special kind of multi-order waveplate, it can meet the required retardation at two wavelength at the same time. It widely used to improve the conversion efficiency in solid double frequency laser device.

- Better Parallelism
- Wide Angle Acceptance
- Better Temperature Bandwidth
- Wide Wavelength Bandwidth
- AR Coated, R<0.2%

Standard Wavelength:
 $\lambda @ 1064nm + \lambda / 2 @ 532nm$, $\lambda / 2 @ 1064nm + \lambda @ 532nm$
 $\lambda @ 532nm + \lambda / 2 @ 355nm$, $\lambda / 2 @ 532nm + \lambda @ 355nm$
 $\lambda @ 800nm + \lambda / 2 @ 400nm$, $\lambda / 2 @ 800nm + \lambda @ 400nm$

Dayoptics Standard Products

P/N#	Diameter(mm)	Unit Price
WPD210	10.0	\$68
WPD212	12.7	\$78
WPD215	15.0	\$88
WPD220	20.0	\$98
WPD225	25.4	\$108
WPD230	30.0	\$118

FRESNAL RHOMB RETARDER

BK7 Fresnal Rhomb Retarder Specifications

Material	BK7 Grade A Optical Glass
Dimension Tolerance	+0.0,-0.2mm
Clear Aperture	>80%
Flatness	$\lambda / 10 @ 632.8nm$
Surface Quality	20/10 Scratch/Dig
Bevel	0.2mm to 0.5mm
Aperature	10x10 mm

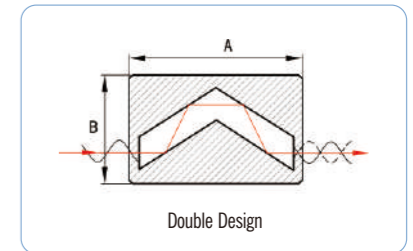
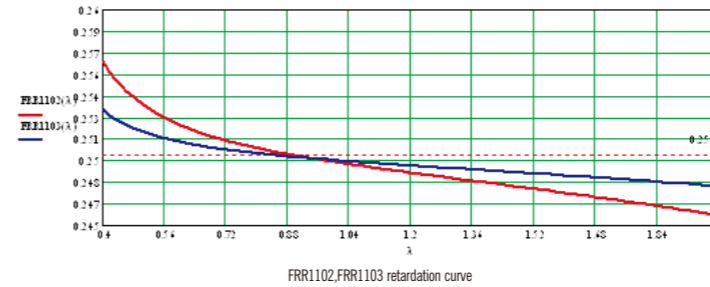
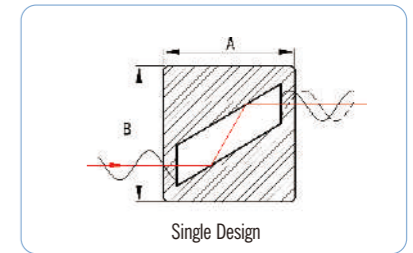

Part No.	Ratardation	Design	Using Wavelength	Mounter Dimension			Unit Price
				A(mm)	B(mm)	H(mm)	
FRR1101	$\lambda / 4$	Single	400-2000nm	35	40	37	\$160
FRR1102	$\lambda / 2$	Double	400-2000nm	64	40	37	\$250
FRR1103	$\lambda / 4$	Double	400-2000nm	140	40	37	\$350

Fused Silica Fresnel Rhomb Retarder Specifications

Material	UV Grade Fused Silica
Dimension Tolerance	+0.0,-0.2mm
Clear Aperture	>80%
Flatness	$\lambda / 10 @ 632.8nm$
Surface Quality	20/10 scratch/dig
Bevel	0.2mm to 0.5mm
Aperature	10x10 mm

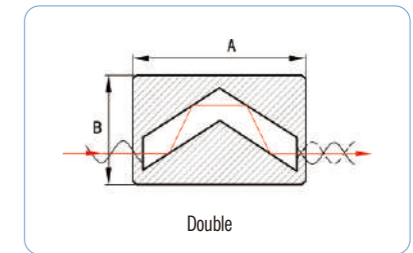
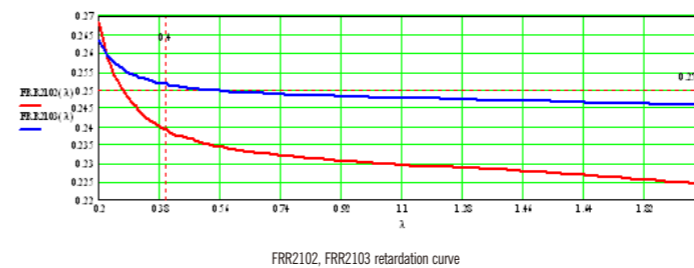
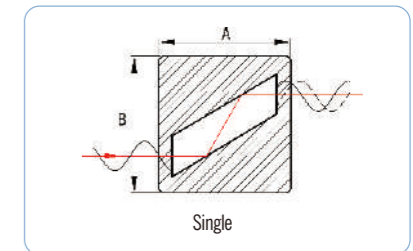

Part No.	Ratardation	Design	Using Wavelength	Mounter Dimension			Unit Price
				A(mm)	B(mm)	H(mm)	
FRR2101	$\lambda / 4$	Single	200-2000nm	35	40	37	\$220
FRR2102	$\lambda / 2$	Double	200-2000nm	64	40	37	\$380
FRR2103	$\lambda / 4$	Double	200-2000nm	140	40	37	\$480

POLARIZATION ROTATOR

Polarization rotators offer 45° or 90° rotation at a number of common laser wavelengths. The optical axis in a polarization rotator is perpendicular to the polished face. The result is that the orientation of in put linearly polarized light is rotated as it propagates through the device.

Specifications

- Wide Angle Acceptance
- Better Temperature Bandwidth
- Wide Wavelength Bandwidth
- AR Coated, R<0.2%

Standard Wavelength: 532nm, 632.8nm, 1064nm

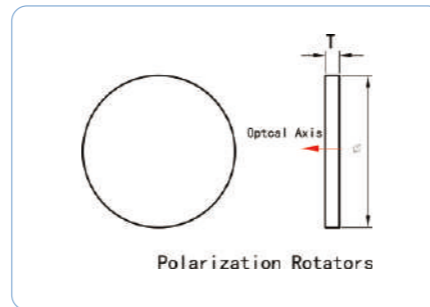

Dayoptics Standard Products

Part No.	Diameter(mm)	Rotation	Unit price
WPR4512	12.7	45°	\$58
WPR4515	15.0	45°	\$68
WPR4520	20.0	45°	\$78
WPR4525	25.4	45°	\$88
WPR9012	12.7	90°	\$98
WPR9015	15.0	90°	\$108
WPR9020	20.0	90°	\$118
WPR9025	25.4	90°	\$128

Order information: 1064nm

HOLDER

Holder for Waveplate

Specifications:

- Material:Black anodized aluminum
- Diameter tolerance: +0/-0.2mm
- Thickness tolerance: +/-0.1mm



P/N#	Diameter(mm)	Thickness(mm)	Aperture(mm)	CA(mm)	Unit price
WH2510	25.4	6.0	10.0	9.0	\$6
WH2512	25.4	6.0	12.7	11.5	\$6.5
WH2515	25.4	6.0	15.0	13.5	\$7
WH3020	30.0	6.0	20.0	18.0	\$8
WH3025	30.0	6.0	25.4	22.8	\$8.5
WH3830	38.1	6.0	30.0	27.0	\$9

Holders for Waveplates

Specifications:

- Material:Black anodized aluminum
- Rotation tolerance:<5°
- Diameter tolerance: +/-0.1mm



P/N#	Width	Height	Length	Diameter(ring holder)	Thickness(ring holder)	Unit price
WRH25	40	60	10	25.4	6.0	\$30
WRH30	45	63	10	30.0	6.0	\$35

POLARIZERS OVERVIEW

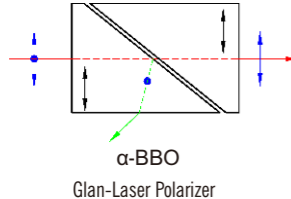
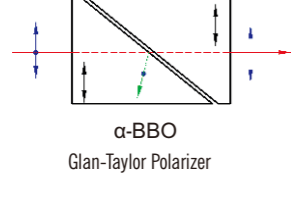
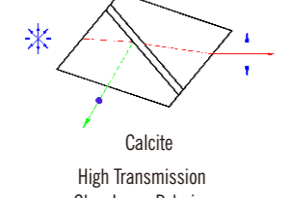
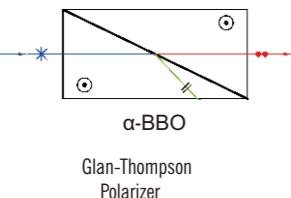
Polarizer	Illustration	Damaged Threshold	Interface	Transmission	Part#	Material	Wavelength(nm)	Extinction Ratio	Angular Field(°)	Page
Glan-Laser Polarizer (PGL)		High Power 500MW/cm ² (with escape windows)	Air-space	Medium	PGL7xxx	Calcite	350-2300	<5x10 ⁻⁵	>7.7	23-24
					PGL6xxx	α-BBO	190-3500	<5x10 ⁻⁵	>6.0	
					PGL8xxx	VO ₁	500-4000	<5x10 ⁻⁵	>6.5	
Glan-Taylor Polarizer (PGT)		Low to Medium 200MW/cm ² (without escape windows)	Air-space	Medium	PGT7xxx	Calcite	350-2300	<5x10 ⁻⁵	>7.7	25-26
					PGT6xxx	α-BBO	190-3500	<5x10 ⁻⁵	>6.0	
					PGT8xxx	VO ₁	500-4000	<5x10 ⁻⁵	>6.5	
High Transmission Glan-Laser Polarizer (PGH)		High Power 500MW/cm ² (with escape windows)	Air-space	High	PGH7xxx	Calcite	350-2300	<5x10 ⁻⁵	>7.7	27-28
					PGH8xxx	VO ₁	500-4000	<5x10 ⁻⁵	>6.5	
Glan-Thompson Polarizer (PGM)		Low Power 100MW/cm ²	Cemented	Medium	PGM71xx	Calcite	350-2300	<5x10 ⁻⁵	14-16	29-30
					PGM72xx	Calcite	350-2300	<5x10 ⁻⁵	25-28	
					PGM6xxx	α-BBO	220-900	<5x10 ⁻⁵	>15	

Polarizer

POLARIZERS OVERVIEW

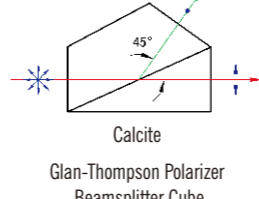
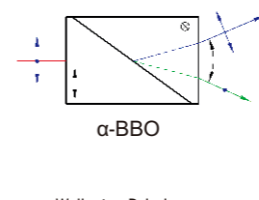
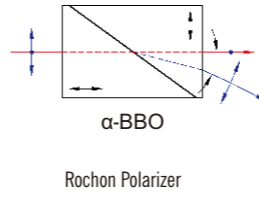
Polarizer	Illustration	Damaged Threshold	Interface	Transmission	Part#	Material	Wavelength(nm)	Extinction Ratio	Angular Field(°)	Page
Glan-Thompson Polarizer Beamsplitter Cube (PGB)		Low to Medium 150MW/cm ²	Cemented	Medium	PGB7xxx	Calcite	350-2300	<5x10 ⁻⁵	14-16	35
Wollaston Polarizer (PWS)		Medium Power 200MW/cm ²	Optical Contact	High	PWS6xxx	α-BBO	190-3500	<5x10 ⁻⁵	15-27	31-32
					PWS9xxx	Quartz	200-2300	<5x10 ⁻⁵	2-3	
		Low Power 100MW/cm ²	Cemented	High	PWS7xxx	Calcite	350-2300	<5x10 ⁻⁵	16.7-22.5	
					PWS8xxx	VO ₁	500-4000	<5x10 ⁻⁵	19.6-23.3	
Rochon Polarizer (PRH)		Low Power 100MW/cm ²	Cemented	High	PRH8xxx	VO ₁	500-4000	<5x10 ⁻⁵	1-2	33-34
					PRH6xxx	α-BBO	190-3500	<5x10 ⁻⁵	8-14	
		Medium Power 200MW/cm ²	Optical Contact	High	PRH9xxx	Quartz	200-2300	<5x10 ⁻⁵	1-2	
PRH5xxx	MgF ₂				120-8500	<1x10 ⁻⁴	1-2			

Polarizer

HIGH POWER GLAN LASER POLARIZER

Glan Laser polarizer is made of two same birefringent material prisms that are assembled with an air space. The polarizer is a modification of the Glan Taylor type and is designed to have less reflection loss at the prism junction. The polarizer with two escape windows allows the rejected beam to escape out of the polarizer, which makes it more desirable for high energy lasers. The surface quality of these faces is relatively poor compare to that of entrance and exit faces. No scratch and dig surface quality specifications are assigned to these faces. The polarized field F1 and F2 of these is shown in the plot below.



Angular Field vs Wavelength

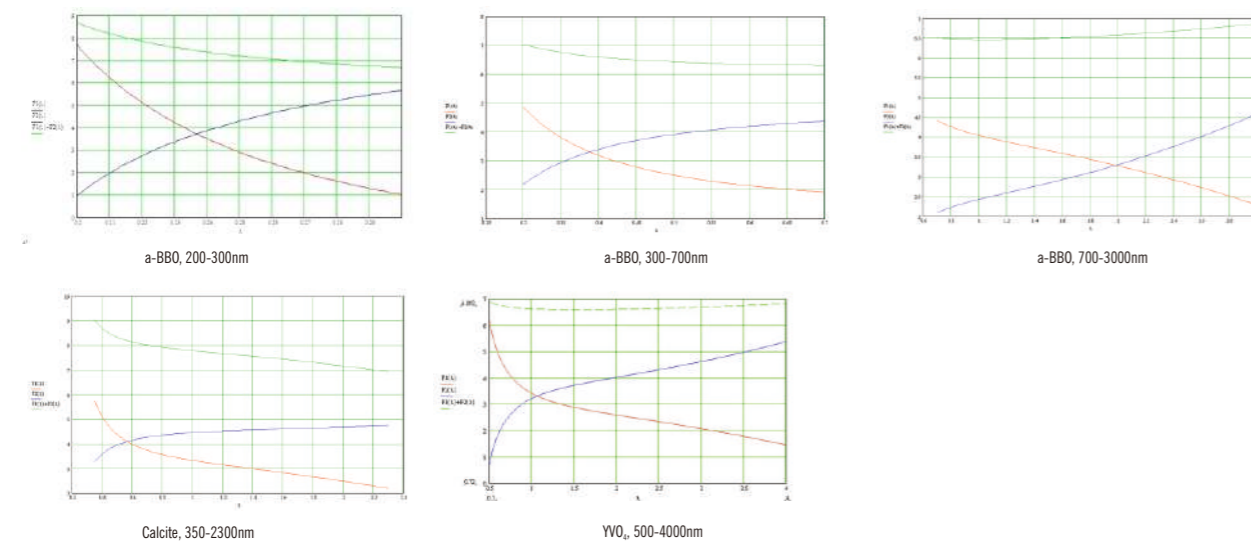

Features

- Air-spaced
- Close to Brewster's Angle Cutting
- High Polarization Purity
- Short Length
- Suitable for low to medium power application where the rejected beam is not required

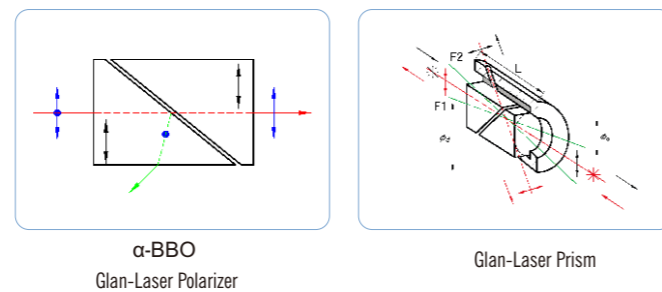

Specifications

Material	a-BBO, Calcite or YVO ₄
Wavelength Range	a-BBO: 190-3500 nm, Calcite: 350-2300 nm, YVO ₄ : 500-4000 nm
Extinction Ratio	Calcite: <math>< 5 \times 10^{-5}</math>; a-BBO: <math>< 5 \times 10^{-6}</math>; YVO ₄ : <math>< 5 \times 10^{-6}</math>
Surface Quality	20/10 Scratch/Dig
Beam Deviation	< 3 arc minutes
Wavefront Distortion	<math>< \lambda / 4 @ 633\text{nm}</math>
Damage Threshold	> 500 MW/cm ²
Coating	Single MgF ₂
Mount	Black Anodized Aluminium

HIGH POWER GLAN LASER POLARIZER

Standard Products

a -BBO High Power Glan Laser Polarizer							
Part No.	Wavelength Rang(nm)	Extinction Ratio	Angular Field(°)	C.A. φ a(mm)	O.D. φ d(mm)	L±0.1(mm)	Unit Price
PGL6206	200-300	<math>< 5 \times 10^{-6}</math>	>6.0	6.0	15.0	29.0	\$294
PGL6208	200-300	<math>< 5 \times 10^{-6}</math>	>6.0	8.0	25.4	31.0	\$338
PGL6210	200-300	<math>< 5 \times 10^{-6}</math>	>6.0	10.0	25.4	31.0	\$421
PGL6215	200-300	<math>< 5 \times 10^{-6}</math>	>6.0	15.0	30.0	38.6	\$668
PGL6220	200-300	<math>< 5 \times 10^{-6}</math>	>6.0	20.0	38.0	48.9	\$998
PGL6306	300-700	<math>< 5 \times 10^{-6}</math>	>6.0	6.0	15.0	25.0	\$294
PGL6308	300-700	<math>< 5 \times 10^{-6}</math>	>6.0	8.0	25.4	25.0	\$338
PGL6310	300-700	<math>< 5 \times 10^{-6}</math>	>6.0	10.0	25.4	26.0	\$421
PGL6315	300-700	<math>< 5 \times 10^{-6}</math>	>6.0	15.0	30.0	33.4	\$668
PGL6320	300-700	<math>< 5 \times 10^{-6}</math>	>6.0	20.0	38.0	43.6	\$998
PGL6706	700-3000	<math>< 5 \times 10^{-6}</math>	>6.0	6.0	15.0	23.0	\$294
PGL6708	700-3000	<math>< 5 \times 10^{-6}</math>	>6.0	8.0	25.4	24.7	\$338
PGL6710	700-3000	<math>< 5 \times 10^{-6}</math>	>6.0	10.0	25.4	25.9	\$421
PGL6715	700-3000	<math>< 5 \times 10^{-6}</math>	>6.0	15.0	30.0	33.0	\$668
PGL6720	700-3000	<math>< 5 \times 10^{-6}</math>	>6.0	20.0	38.0	43.6	\$968

Calcite High Power Glan Laser Polarizer							
Part No.	Wavelength Rang(nm)	Extinction Ratio	Angular Field(°)	C.A. φ a(mm)	O.D. φ d(mm)	L±0.1(mm)	Unit Price
PGL7006	350-2300	<math>< 5 \times 10^{-5}</math>	>7.7	6.0	15.0	21.0	\$182
PGL7008	350-2300	<math>< 5 \times 10^{-5}</math>	>7.7	8.0	25.4	24.5	\$221
PGL7010	350-2300	<math>< 5 \times 10^{-5}</math>	>7.7	10.0	25.4	26.2	\$268
PGL7015	350-2300	<math>< 5 \times 10^{-5}</math>	>7.7	15.0	30.0	33.3	\$418
PGL7020	350-2300	<math>< 5 \times 10^{-5}</math>	>7.7	20.0	38.0	42.3	\$718

YVO4 High Power Glan Laser Polarizer							
Part No.	Wavelength Rang(nm)	Extinction Ratio	Angular Field(°)	C.A. φ a(mm)	O.D. φ d(mm)	L±0.1(mm)	Unit Price
PGL8006	500-4000	<math>< 5 \times 10^{-6}</math>	>6.5	6.0	15.0	15.5	\$238
PGL8008	500-4000	<math>< 5 \times 10^{-6}</math>	>6.5	8.0	25.4	19.0	\$304
PGL8010	500-4000	<math>< 5 \times 10^{-6}</math>	>6.5	10.0	25.4	22.5	\$376
PGL8015	500-4000	<math>< 5 \times 10^{-6}</math>	>6.5	15.0	38.0	31.0	\$628

GLAN TAYLOR POLARIZER

Glan Taylor polarizer is made of two same birefringent material prisms that are assembled with an air space. Its length to aperture ratio which is less than 1.0 makes it a relatively thin polarizer. The polarizer with no side escape windows is suitable for low to medium power application where the side rejected beams are not required. The angular field of different materials of polarizers is listed below for comparison.

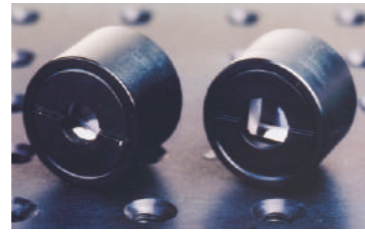

Angular Field vs Wavelength

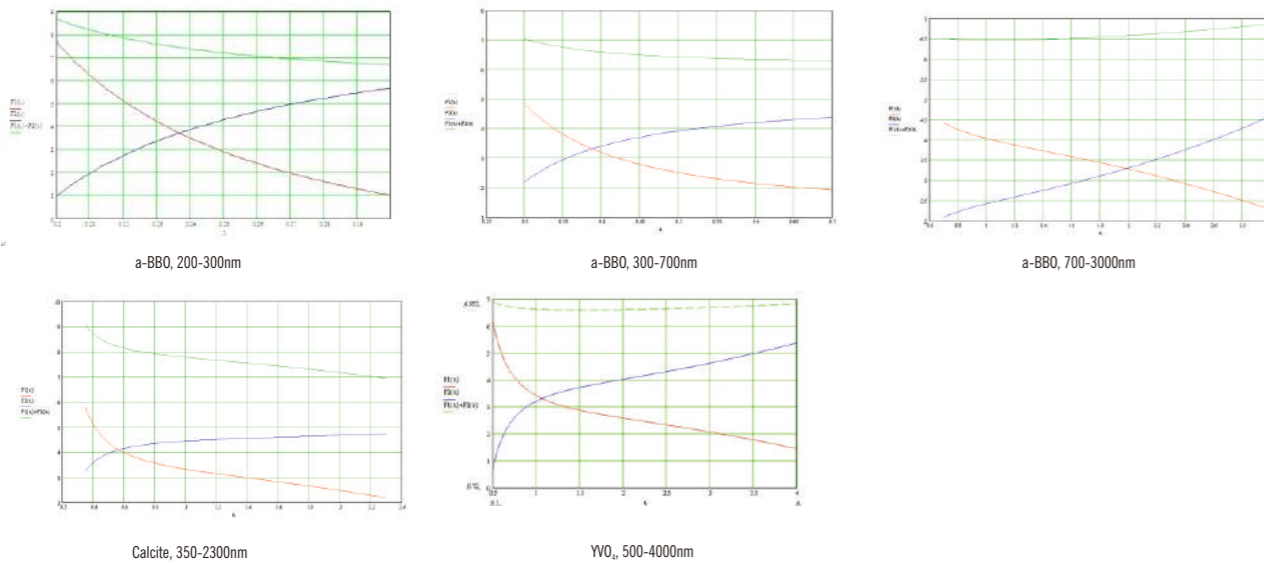

Features

- Air-spaced
- Close to Brewster's Angle Cutting
- High Polarization Purity
- Short Length
- Suitable for low to medium power application where the rejected beam is not required

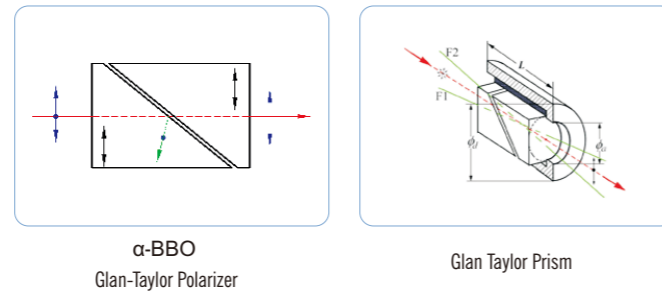

Specifications

Material	a-BBO, Calcite or YVO ₄
Wavelength Range	a-BBO: 190-3500 nm, Calcite: 350-2300 nm, YVO ₄ : 500-4000 nm
Extinction Ratio	Calcite: <math>< 5 \times 10^{-5}</math>; a-BBO: <math>< 5 \times 10^{-6}</math>; YVO ₄ : <math>< 5 \times 10^{-6}</math>
Surface Quality	20/10 Scratch/Dig
Beam Deviation	< 3 arc minutes
Wavefront Distortion	<math>< \lambda / 4 @ 633\text{nm}</math>
Damage Threshold	> 200 MW/cm ²
Coating	Single MgF ₂
Mount	Black Anodized Aluminium

GLAN TAYLOR POLARIZER

Standard Products

α-BBO Glan Taylor Polarizer							
Part No.	Wavelength Rang(nm)	Extinction Ratio	Angular Field(°)	C.A. φ a(mm)	O.D. φ d(mm)	L±0.1(mm)	Unit Price
PGT6206	200-300	<math>< 5 \times 10^{-6}</math>	>6.0	6.0	15.0	15.0	\$238
PGT6208	200-300	<math>< 5 \times 10^{-6}</math>	>6.0	8.0	25.4	17.0	\$279
PGT6210	200-300	<math>< 5 \times 10^{-6}</math>	>6.0	10.0	25.4	19.0	\$358
PGT6215	200-300	<math>< 5 \times 10^{-6}</math>	>6.0	15.0	30.0	23.0	\$598
PGT6220	200-300	<math>< 5 \times 10^{-6}</math>	>6.0	20.0	38.0	29.0	\$898
PGT6306	300-700	<math>< 5 \times 10^{-6}</math>	>6.0	6.0	15.0	15.0	\$238
PGT6308	300-700	<math>< 5 \times 10^{-6}</math>	>6.0	8.0	25.4	17.0	\$279
PGT6310	300-700	<math>< 5 \times 10^{-6}</math>	>6.0	10.0	25.4	19.0	\$358
PGT6315	300-700	<math>< 5 \times 10^{-6}</math>	>6.0	15.0	30.0	23.0	\$598
PGT6320	300-700	<math>< 5 \times 10^{-6}</math>	>6.0	20.0	38.0	29.0	\$898
PGT6706	700-3000	<math>< 5 \times 10^{-6}</math>	>6.0	6.0	15.0	15.0	\$238
PGT6708	700-3000	<math>< 5 \times 10^{-6}</math>	>6.0	8.0	25.4	17.0	\$279
PGT6710	700-3000	<math>< 5 \times 10^{-6}</math>	>6.0	10.0	25.4	19.0	\$358
PGT6715	700-3000	<math>< 5 \times 10^{-6}</math>	>6.0	15.0	30.0	23.0	\$598
PGT6720	700-3000	<math>< 5 \times 10^{-6}</math>	>6.0	20.0	38.0	29.0	\$898

Calcite Glan Taylor Polarizer							
Part No.	Wavelength Rang(nm)	Extinction Ratio	Angular Field(°)	C.A. φ a(mm)	O.D. φ d(mm)	L±0.1(mm)	Unit Price
PGT7006	350-2300	<math>< 5 \times 10^{-5}</math>	>7.7	6.0	15.0	15.0	\$166
PGT7008	350-2300	<math>< 5 \times 10^{-5}</math>	>7.7	8.0	25.4	17.0	\$194
PGT7010	350-2300	<math>< 5 \times 10^{-5}</math>	>7.7	10.0	25.4	19.0	\$250
PGT7015	350-2300	<math>< 5 \times 10^{-5}</math>	>7.7	15.0	30.0	23.0	\$389
PGT7020	350-2300	<math>< 5 \times 10^{-5}</math>	>7.7	20.0	38.0	29.0	\$678

YVO4 Glan Taylor Polarizer							
Part No.	Wavelength Rang(nm)	Extinction Ratio	Angular Field(°)	C.A. φ a(mm)	O.D. φ d(mm)	L±0.1(mm)	Unit Price
PGT8006	500-4000	<math>< 5 \times 10^{-6}</math>	>6.5	6.0	15.0	12.0	\$190
PGT8008	500-4000	<math>< 5 \times 10^{-6}</math>	>6.5	8.0	25.4	15.0	\$228
PGT8010	500-4000	<math>< 5 \times 10^{-6}</math>	>6.5	10.0	25.4	17.0	\$304
PGT8015	500-4000	<math>< 5 \times 10^{-6}</math>	>6.5	15.0	30.0	20.0	\$518
PGT8020	500-4000	<math>< 5 \times 10^{-6}</math>	>6.5	20.0	38.0	25.0	\$798

HIGH TRANSMSSION POLARIZER

High Transmission Glan Laser Polarizers (PGH) is a special type of Glan Laser Polarizers. The incidence angle of the PGH is Brewster angle cut which can greatly improve the transmission ray up to 98% in a wide range of wavelength without coating. The polarizer can be made from Calcite and YVO₄ crystals. In order to get high transmission of wide range of wavelength, the polarizers are not recommended to use for large acceptance angle. Typically used is within $\pm 5^\circ$.

Features

- UV High Power Application, $>20\text{J}/\text{cm}^2@1064\text{nm}, 10\text{ns}, 20\text{Hz}$
- High Transmission: $T > 95\%$
- High Extinction Ratio, Wide Acceptance Angle
- Material: Calcite, YVO₄
- Dimension: $3 \times 3\text{mm} \sim 20 \times 20\text{mm}$

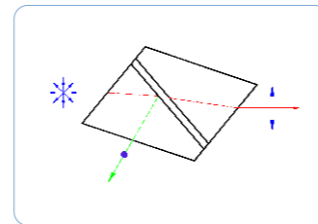
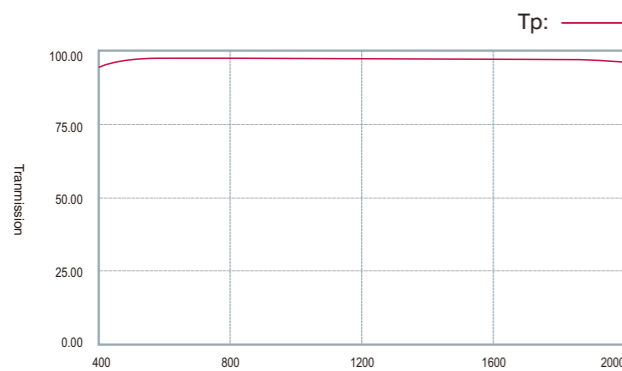

Calcite
High Transmission
Glan-Laser Polarizer

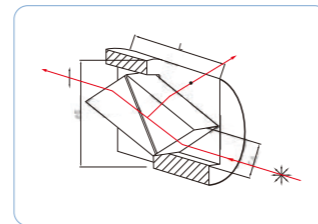

Glan Laser Polarizer High Transmission
Curve Brewster Angle

HIGH TRANSMSSION POLARIZER

Standard Products

Calcite High Transmission Glan Laser Polarizer								
Part No.	Wavelength Rang	Extinction Ratio	Angular Field	C.A.f a (mm)	O.D.f d (mm)	L ± 0.1 (mm)	Beam offset	Unit Price
PGH7006	350-2300	$<5 \times 10^{-5}$	$\sim 5^\circ$ (typical)	6.0	25.4	25.0	5.5mm	\$258
PGH7008	350-2300	$<5 \times 10^{-5}$	$\sim 5^\circ$ (typical)	8.0	25.4	32.0	7.8mm	\$298
PGH7010	350-2300	$<5 \times 10^{-5}$	$\sim 5^\circ$ (typical)	10.0	30.0	38.0	9.3mm	\$368
PGH7015	350-2300	$<5 \times 10^{-5}$	$\sim 5^\circ$ (typical)	15.0	38.0	54.0	14.0mm	\$518
YVO4 High Transmission Glan Laser Polarizer								
Part No.	Wavelength Rang	Extinction Ratio	Angular Field	C.A.f a (mm)	O.D.f d (mm)	L ± 0.1 (mm)	Beam offset	Unit Price
PGH8006	500-4000	$<5 \times 10^{-6}$	$\sim 5^\circ$ (typical)	6.0	25.4	28.0	5.5mm	\$258
PGH8008	500-4000	$<5 \times 10^{-6}$	$\sim 5^\circ$ (typical)	8.0	30.0	38.0	13.3mm	\$428
PGH8010	500-4000	$<5 \times 10^{-6}$	$\sim 5^\circ$ (typical)	10.0	38.0	45.0	16.0mm	\$518

Specifications

Material	Calcite, YVO ₄
Wavelength Range	Calcite: 350-2300nm, YVO ₄ : 500-4000nm
Extinction Ratio	Calcite: $<5 \times 10^{-5}$, YVO ₄ : $<5 \times 10^{-6}$
Transmission	$>98\%$ (typical)
Surface Quality	20/10 Scratch/Dig
Beam Deviation	<3 arc minutes
Waveform Distortion	$\lambda/4@633\text{nm}$
Damage Threshold	$>500 \text{ MW}/\text{cm}^2$
Coating	Uncoated
Mount	Black Anodized Aluminium

GLAN THOMPSON POLARIZER

Glan Thompson polarizer is made of two calcite prisms or two α -BBO prisms cemented together. Two types of Glan Thompsons are available. One is the standard form and the other is the long form. Their length to aperture ratios are 2.5 : 1 and 3.0 : 1 respectively. Glan Thompson polarizers tend to have higher extinction ratio than air spaced polarizers. In the ultra violet spectrum, their transmission is limited by absorption in birefringent materials as well as the cement layer. α -BBO polarizers and Calcite polarizers can be used from about 220 to 900nm and 350 to 2300 nm respectively.

The polarizers have the widest field angle of any design. The standard form of this polarizer with 2.5:1 length to aperture ratio has a full acceptance cone angle of more than 15° @ 589nm, symmetric about the input axis, while the long form with 3:1 ratio has a field angle $>26^\circ$. The polarized field F1 and F2 of all these is shown in the plot below.

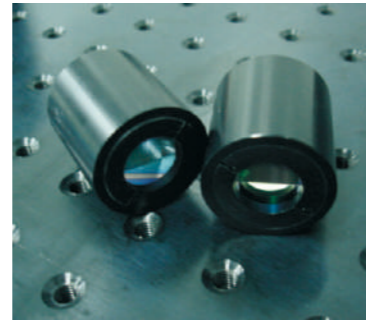

Angular Field vs Wavelength

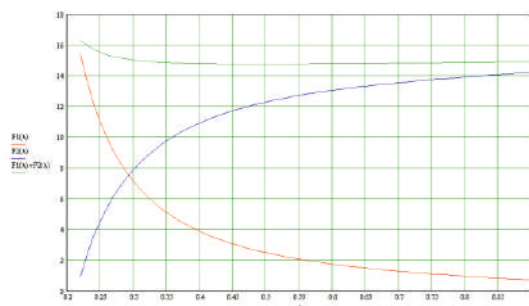

α -BBO, 220-900nm

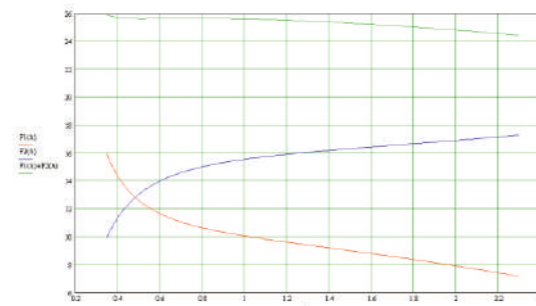

Calcite: L/A=2.5 (350-2300nm)

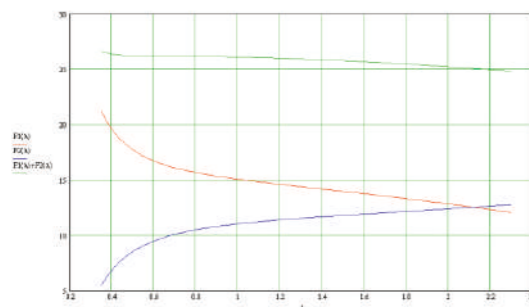

Calcite: L/A=3 (350-2300nm)

Specifications

Material	α -BBO, Calcite
Wavelength Range	α -BBO: 200-900 nm, Calcite: 350-2300 nm
Extinction Ratio	Calcite: $<5 \times 10^{-5}$; α -BBO: $<5 \times 10^{-6}$
Surface Quality	20/10 Scratch/Dig
Beam Deviation	< 3 arc minutes
Wavefront Distortion	$< \lambda/4$ @ 633nm
Damage Threshold	> 200 MW/cm ²
Coating	Single MgF ₂
Mount	Black Anodized Aluminium

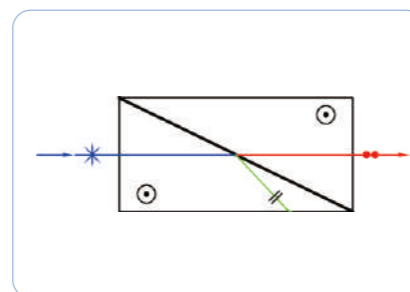

α -BBO
Glan-Thompson Polarizer

GLAN THOMPSON POLARIZER

Standard Products

a-BBO Glan Thompson Polarizer Special for DUV, Visible and NIR(200-900nm)							
Part No.	L(Material)/CA	Extinction Ratio	Angular Field(°)	C.A. ϕ a(mm)	O.D. ϕ d(mm)	L \pm 0.1(mm)	Unit Price
PGM6006	1.6	$<5 \times 10^{-6}$	>15	6	15	18	\$398
PGM6008	1.6	$<5 \times 10^{-6}$	>15	8	25.4	21	\$438
PGM6010	1.6	$<5 \times 10^{-6}$	>15	10	25.4	24.5	\$538
PGM6012	1.6	$<5 \times 10^{-6}$	>15	12.7	25.4	29	\$648
PGM6015	1.6	$<5 \times 10^{-6}$	>15	15	30	33	\$808
PGM6020	1.6	$<5 \times 10^{-6}$	>15	20	38	41.5	\$1108

Calcite Glan Thompson Polarizer (350-2300nm)							
Part No.	L(Material)/CA	Extinction Ratio	Angular Field(°)	C.A. ϕ a(mm)	O.D. ϕ d(mm)	L \pm 0.1(mm)	Unit Price
PGM7106	2.5	$<5 \times 10^{-5}$	14-16	6	15	23	\$238
PGM7108	2.5	$<5 \times 10^{-5}$	14-16	8	25.4	28	\$268
PGM7110	2.5	$<5 \times 10^{-5}$	14-16	10	25.4	33	\$318
PGM7112	2.5	$<5 \times 10^{-5}$	14-16	12.7	25.4	39	\$368
PGM7115	2.5	$<5 \times 10^{-5}$	14-16	15	30	45.5	\$498
PGM7206	3	$<5 \times 10^{-5}$	25-28	6	15	26	\$308
PGM7208	3	$<5 \times 10^{-5}$	25-28	8	25.4	32	\$338
PGM7210	3	$<5 \times 10^{-5}$	25-28	10	25.4	38	\$458
PGM7212	3	$<5 \times 10^{-5}$	25-28	12.7	25.4	46	\$528
PGM7215	3	$<5 \times 10^{-5}$	25-28	15	30	53	\$628

Order information: 450-650nm PBS506-450-650nm

WOLLASTON POLARIZER

Wollaston polarizer is made of two birefringent material prisms that are cemented together. The deviations of the ordinary and extraordinary beams are nearly symmetrical about the input beam axis, so that the Wollaston polarizing beam splitter has approximately twice the deviation of the Rochon. The separation angle exhibits chromatic dispersion, as shown in the plot below. Any separation angle can be designed upon requirement. The separation angle of standard products vs wavelength is shown in the plot below.



Angular Field vs Wavelength

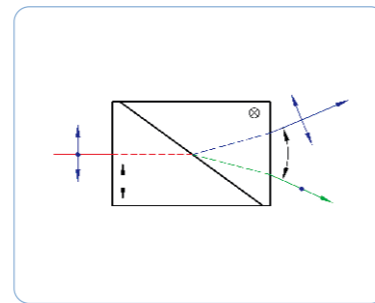
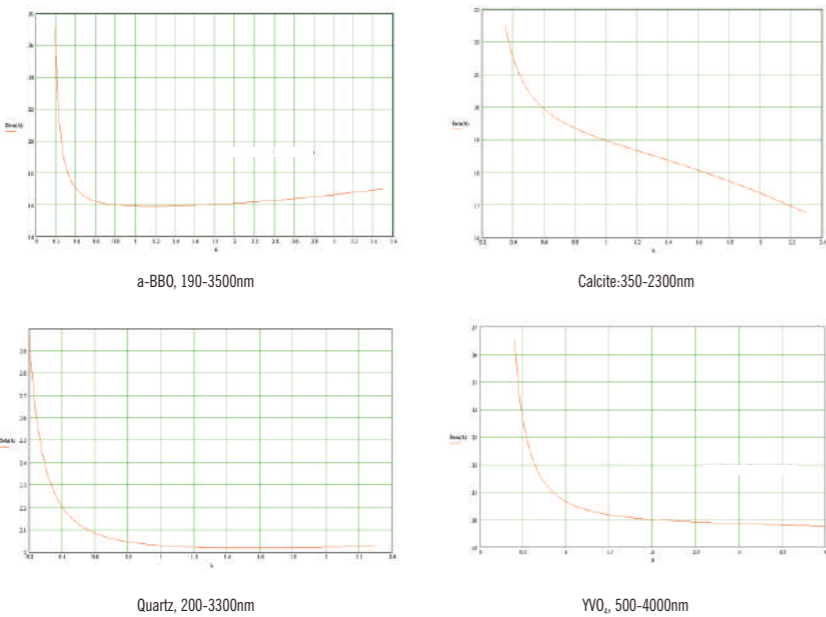

α-BBO Wollaston Polarizer

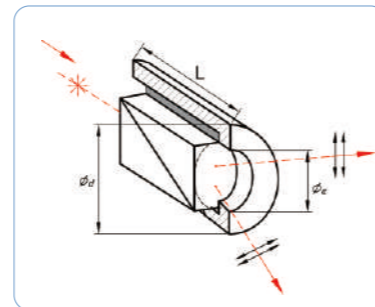

Specifications

Material	α -BBO, Calcite, YVO ₄ , Quartz
Wavelength Range	α -BBO:190-3500 nm, Calcite:350-2300nm, YVO ₄ :500-4000nm, Quartz:200-2300nm
Extinction Ratio	Calcite, Quartz:<5x10 ⁻⁵ ; α-BBO, YVO ₄ :<5x10 ⁻⁶
Surface Quality	20/10 Scratch/Dig
Beam Deviation	< 3 arc minutes
Wavefront Distortion	< λ /4@633nm
Damage Threshold	>500 MW/cm ²
Coating	Single MgF ₂
Mount	Black Anodized Aluminium

WOLLASTON POLARIZER

Standard Products

α -BBO Wollaston Polarizer						
Part No.	Extinction Ratio	Separate Field(°)	C.A. φ a(mm)	O.D. φ d(mm)	L ± 0.1 (mm)	Unit Price
PWS6006	<5x10 ⁻⁶	15-27 16@800nm	6.0	15.0	14.0	\$262
PWS6008	<5x10 ⁻⁶	15-27 16@800nm	8.0	25.4	16.0	\$338
PWS6010	<5x10 ⁻⁶	15-27 16@800nm	10.0	25.4	18.0	\$448
PWS6015	<5x10 ⁻⁶	15-27 16@800nm	15.0	30.0	23.0	\$708
PWS6020	<5x10 ⁻⁶	15-27 16@800nm	20.0	38.0	28.0	\$1128

Calcite Wollaston Polarizer						
Part No.	Extinction Ratio	Separate Field(°)	C.A. φ a(mm)	O.D. φ d(mm)	L ± 0.1 (mm)	Unit Price
PWS7006	<5x10 ⁻⁵	16.7-22.5 19@980nm	6.0	15.0	14.0	\$174
PWS7008	<5x10 ⁻⁵	16.7-22.5 19@980nm	8.0	25.4	16.0	\$219
PWS7010	<5x10 ⁻⁵	16.7-22.5 19@980nm	10.0	25.4	18.0	\$268
PWS7015	<5x10 ⁻⁵	16.7-22.5 19@980nm	15.0	30.0	23.0	\$508
PWS7020	<5x10 ⁻⁵	16.7-22.5 19@980nm	20.0	38.0	28.0	\$808

Quartz Wollaston Polarizer						
Part No.	Extinction Ratio	Separate Field(°)	C.A. φ a(mm)	O.D. φ d(mm)	L ± 0.1 (mm)	Unit Price
PWS9006	<5x10 ⁻⁵	2-3 2@1064nm	6.0	15.0	20.0	\$158
PWS9008	<5x10 ⁻⁵	2-3 2@1064nm	8.0	25.4	24.0	\$202
PWS9010	<5x10 ⁻⁵	2-3 2@1064nm	10.0	25.4	28.0	\$250
PWS9015	<5x10 ⁻⁵	2-3 2@1064nm	15.0	30.0	38.0	\$388
PWS9020	<5x10 ⁻⁵	2-3 2@1064nm	20.0	38.0	48.0	\$658

YVO4 Wollaston Polarizer						
Part No.	Extinction Ratio	Separate Field(°)	C.A. φ a(mm)	O.D. φ d(mm)	L ± 0.1 (mm)	Unit Price
PWS8006	<5x10 ⁻⁶	19.6-23.3 20@1550nm	6.0	15.0	14.0	\$223
PWS8008	<5x10 ⁻⁶	19.6-23.3 20@1550nm	8.0	25.4	16.0	\$268
PWS8010	<5x10 ⁻⁶	19.6-23.3 20@1550nm	10.0	25.4	16.0	\$359
PWS8015	<5x10 ⁻⁶	19.6-23.3 20@1550nm	15.0	30.0	20.0	\$588
PWS8020	<5x10 ⁻⁶	19.6-23.3 20@1550nm	20.0	38.0	25.0	\$968

Polarizer

Polarizer

ROCHON POLARIZER

Rochon polarizer is one of the earliest designs, which is made of two birefringent material prisms cemented or optical contacted together. Both ordinary and extraordinary beams propagate collinearly down the optic axis in the first prism under the ordinary refractive index. Upon entering the second prism the ordinary beam experiences the same refractive index and continues undeviated. The extra-ordinary beam, however, now has a lower refractive index and is refracted at the interface. Any separation angle can be designed for specific wavelength upon requirement.



Angular Field vs Wavelength

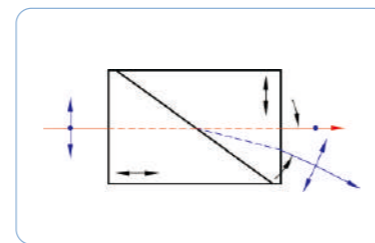
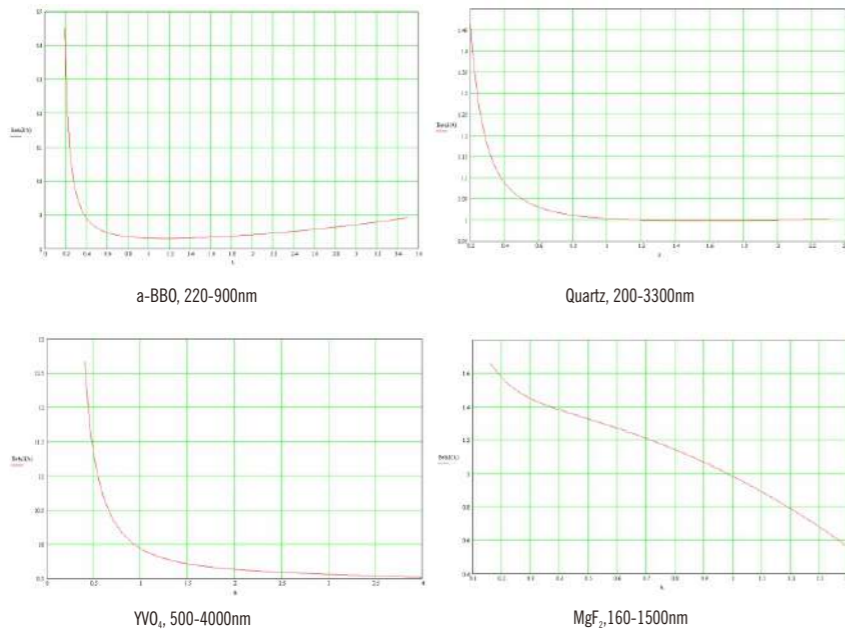

α -BBO
Rochon Polarizer

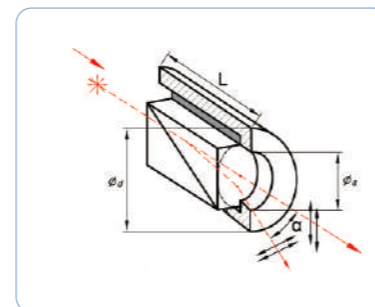

Rochon Prism

Specifications

Material	α -BBO, Calcite, YVO ₄ , Quartz, MgF ₂
Wavelength Range	a-BBO:190-3500nm, YVO ₄ :500-4000nm, Quartz:200-2300nm, MgF ₂ :130-7000nm
Extinction Ratio	Quartz: $<5 \times 10^{-5}$; α -BBO, YVO ₄ : $<5 \times 10^{-6}$, MgF ₂ : $<10^{-4}$
Parallelism	<1 arc Min
Surface Quality	20/10 Scratch/Dig
Beam Deviation	<3 arc minutes
Wavefront Distortion	$< \lambda/4$ @ 633nm
Damage Threshold	>500 MW/cm ²
Coating	Single MgF ₂
Mount	Black Anodized Aluminium

ROCHON POLARIZER

Standard Products

MgF ₂ Rochon Polarizer						
Part No.	Extinction Ratio	Separate Field (°)	C.A. ϕ a(mm)	O.D. ϕ d(mm)	L ± 0.1 (mm)	Unit price
PRH5006	$<1 \times 10^{-4}$	1.0-2 1@980nm	6.0	15.0	14.0	\$230
PRH5008	$<1 \times 10^{-4}$	1.0-2 1@980nm	8.0	25.4	18.0	\$313
PRH5010	$<1 \times 10^{-4}$	1.0-2 1@980nm	10.0	25.4	28.0	\$403
PRH5015	$<1 \times 10^{-4}$	1.0-2 1@980nm	15.0	30.0	38.0	\$668
PRH5020	$<1 \times 10^{-4}$	1.0-2 1@980nm	20.0	38.0	48.0	\$998

α -BBO Rochon Polarizer						
Part No.	Extinction Ratio	Separate Field (°)	C.A. ϕ a(mm)	O.D. ϕ d(mm)	L ± 0.1 (mm)	Unit price
PRH6006	$<5 \times 10^{-6}$	8.0-14 8@800nm	6.0	15.0	14.0	\$318
PRH6008	$<5 \times 10^{-6}$	8.0-14 8@800nm	8.0	25.4	16.0	\$372
PRH6010	$<5 \times 10^{-6}$	8.0-14 8@800nm	10.0	25.4	18.0	\$502
PRH6015	$<5 \times 10^{-6}$	8.0-14 8@800nm	15.0	30.0	23.0	\$858
PRH6020	$<5 \times 10^{-6}$	8.0-14 8@800nm	20.0	38.0	28.0	\$1398

Quartz Rochon Polarizer						
Part No.	Extinction Ratio	Separate Field (°)	C.A. ϕ a(mm)	O.D. ϕ d(mm)	L ± 0.1 (mm)	Unit price
PRH9006	$<5 \times 10^{-5}$	1.0-1.5 1@1064nm	6.0	15.0	20.0	\$206
PRH9008	$<5 \times 10^{-5}$	1.0-1.5 1@1064nm	8.0	25.4	24.0	\$270
PRH9010	$<5 \times 10^{-5}$	1.0-1.5 1@1064nm	10.0	25.4	28.0	\$349
PRH9015	$<5 \times 10^{-5}$	1.0-1.5 1@1064nm	15.0	30.0	38.0	\$588
PRH9020	$<5 \times 10^{-5}$	1.0-1.5 1@1064nm	20.0	38.0	48.0	\$898

YVO ₄ Rochon Polarizer						
Part No.	Extinction Ratio	Separate Field (°)	C.A. ϕ a(mm)	O.D. ϕ d(mm)	L ± 0.1 (mm)	Unit price
PRH8006	$<5 \times 10^{-6}$	9.8-13.0 10@1550nm	6.0	15.0	14.0	\$259
PRH8008	$<5 \times 10^{-6}$	9.8-13.0 10@1550nm	8.0	25.4	16.0	\$331
PRH8010	$<5 \times 10^{-6}$	9.8-13.0 10@1550nm	10.0	25.4	16.0	\$426
PRH8015	$<5 \times 10^{-6}$	9.8-13.0 10@1550nm	15.0	30.0	20.0	\$668
PRH8020	$<5 \times 10^{-6}$	9.8-13.0 10@1550nm	20.0	38.0	25.0	\$998

35 GLAN THOMPSON POLARIZER BEAMSPLITTER CUBE

Glan Thompson polarizer Beamsplitter Cube is made of two Calcite prisms or two a-BBO prisms cemented together. It has high extinction ratio below 5×10^{-5} is obtained. The Calcite type can be used in the range of the 350-2300nm, and a-BBO crystal usable in the range of the 220-900nm. It can separate the nature light for O polarized light and E polarized light, and the separate angle is 45° . Since there are two ports, the prism can also be used by replacing the input and output direction.

The polarizers have the widest field angle of any design. The standard form of this polarizer with 2.5:1 length to aperture ratio has a full acceptance cone angle of more than 15° @ 589nm, symmetric about the input axis, while the long form with 3:1 ratio has a field angle $>26^\circ$. The polarized field F1 and F2 of all these is shown in the plot below.



Angular Field vs Wavelength

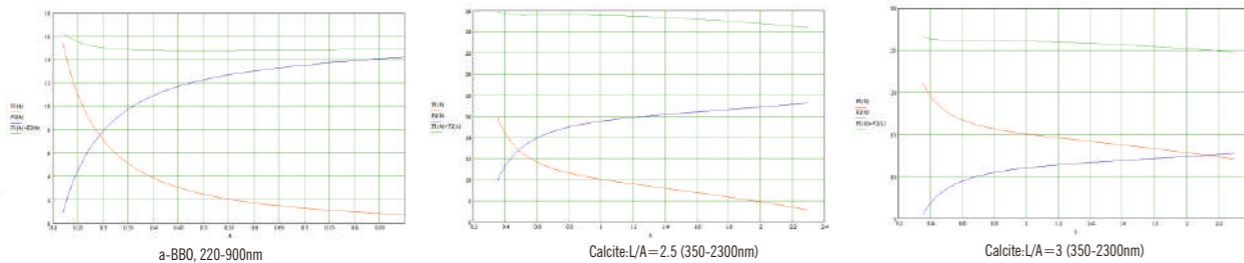

Specifications

Material	a-BBO, Calcite
Wavelength Range	a-BBO: 200-900 nm, Calcite: 350-2300 nm
Extinction Ratio	a-BBO: $<5 \times 10^{-5}$; Calcite: $<5 \times 10^{-6}$
Surface Quality	20-10 Scratch/Dig
Beam Deviation	< 3 arc minutes
Wavefront Distortion	$< \lambda / 4 @ 633\text{nm}$
Separate Angle	$45^\circ \pm 0.5^\circ$
Damage Threshold	$> 200 \text{ MW/cm}^2$
Coating	Single MgF_2
Mount	Black Anodized Aluminium

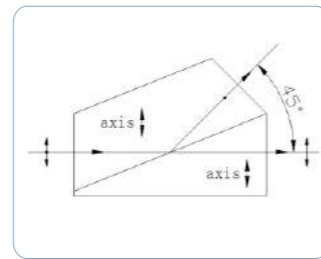

α -BBO
Glan-Thompson Polarizer

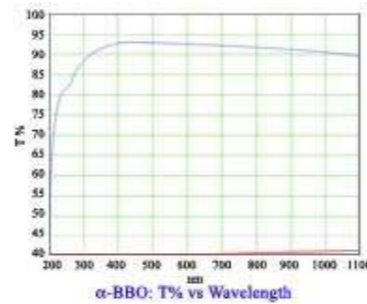

GLAN THOMPSON POLARIZERS Standard Products

a-BBO Glan Thompson Polarizer Beamsplitter Cube Special for DUV, Visible and NIR(220-900nm)							
Part No.	L(Material)/CA	Extinction Ratio	Angular Field (°)	C.A. ϕ a(mm)	O.D. ϕ d(mm)	L \pm 0.1(mm)	Unit Price
PGB6006	1.6	$<5 \times 10^{-6}$	>15	6	25.3	15	\$538
PGB6008	1.6	$<5 \times 10^{-6}$	>15	8	30	18	\$598
PGB6010	1.6	$<5 \times 10^{-6}$	>15	10	38.1	22	\$688
PGB6012	1.6	$<5 \times 10^{-6}$	>15	12.7	50.8	26	\$838
PGB6015	1.6	$<5 \times 10^{-6}$	>15	15	50.8	30	\$1068

Calcite Glan Thompson Polarizer hBeamsplitter Cube (350-2300nm)							
Part No.	L(Material)/CA	Extinction Ratio	Angular Field (°)	C.A. ϕ a(mm)	O.D. ϕ d(mm)	L \pm 0.1(mm)	Unit Price
PGB7006	2.5	$<5 \times 10^{-5}$	14-16	6	25.4	20	\$388
PGB7008	2.5	$<5 \times 10^{-5}$	14-16	8	30	25	\$458
PGB7010	2.5	$<5 \times 10^{-5}$	14-16	10	38.1	30	\$568
PGB7012	2.5	$<5 \times 10^{-5}$	14-16	12.7	50.8	37	\$658
PGB7015	2.5	$<5 \times 10^{-5}$	14-16	15	50.8	43	\$788

36 THIN FILM POLARIZER

Dayoptics thin film polarizers based on a coating is made up of particular birefringent materials which has polarizing properties. The coating is designed under Brewster angle.

Brewster Angle: For light incident on a plane boundary between two regions having different refractive indices, the angle of incidence at which the reflectance is zero for light that has its electrical field vector in the plane defined by the direction of propagation and the normal to the surface. For propagation from medium 1 to medium 2, Brewster's angle is given as $\arctan(n_2/n_1)$.

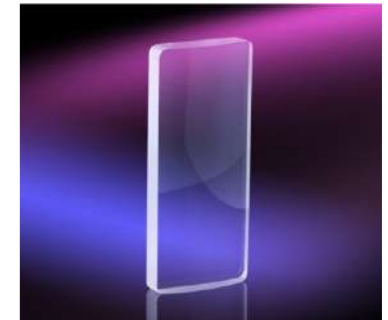

Specifications

Material	BK7
Two surfaces polished	
Surface Quality	40/20 Both Sides
Flatness	$\lambda / 8 @ 633\text{nm}$
Other surfaces are fine ground	
Chamfer	$< 0.3 \times 45^\circ$
One Side Coating	$T_p > 97\%$ and $T_s < 0.05\%$ @ 1064nm (Brewster angle incidence 56.4deg.)
Standard Products	
Dimension	28.6x14.3 mm
Thickness	3 mm
Standard Code	PTF1001

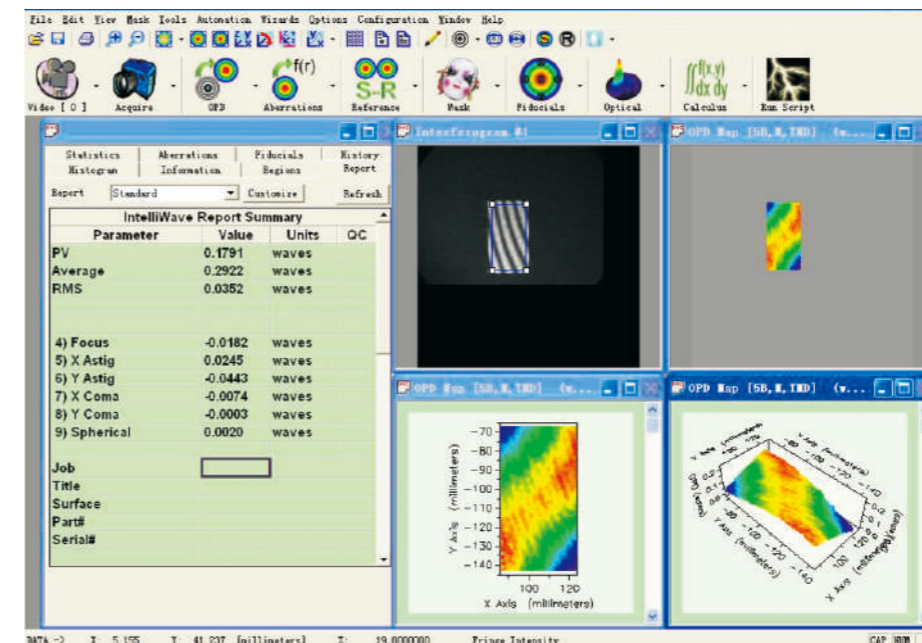
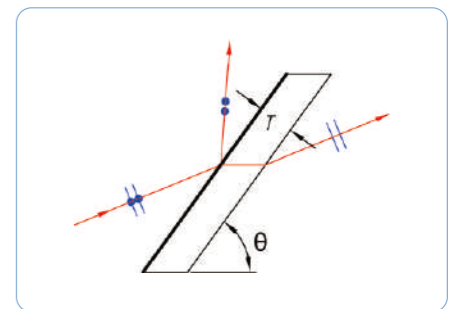

The flatness of Thin Film Polarizer is inspected by our interferometer.

Thin film Polarizer-45°

Dayoptics has newly developed thin film polarizer based on 45deg. Incidence. We can assure high transmission >95% and high reflection >99%. Ask Dayoptics' sales for whatever you need.

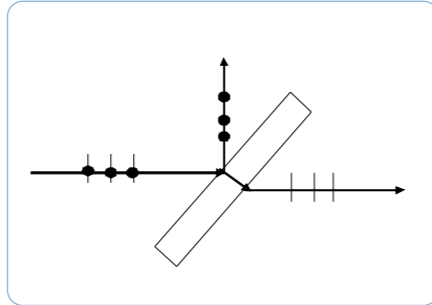
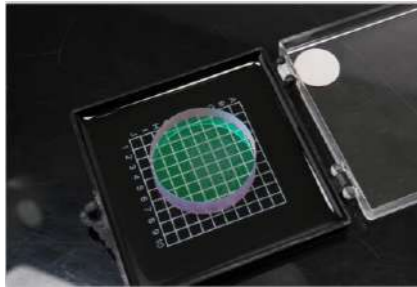

Specifications

Material	Fused Silica
Two surfaces polished	
Surface Quality	40/20 Both Sides
Flatness	$\lambda / 8 @ 633\text{nm}$
Other surfaces are fine ground	
Chamfer	<0.3x45°
Coating specification	Tp>95% & Rs>99% @ 355 +/-3nm, AOI=45deg +/-1 deg.
	Tp>95% & Rs>99% @ W +/-5nm, AOI=45deg +/-1 deg. 800nm>W>400nm
	Tp>95% & Rs>99% @ W +/-10nm, AOI=45deg +/-1 deg. 1100nm>W>800nm

Typical Coating Curve:

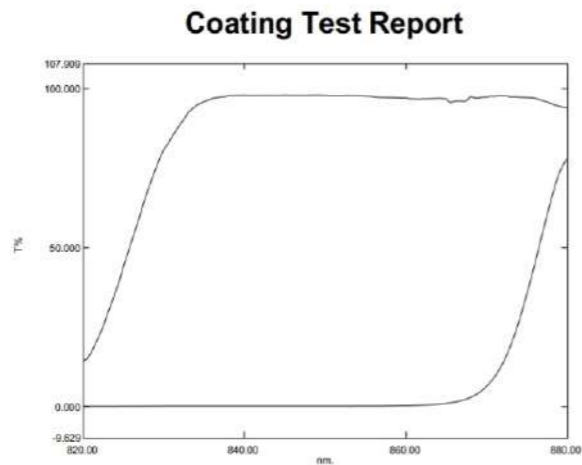

Tp>95% & Rs>99% @ 850 +/-10nm, AOI=45deg +/-1 deg.

ETALON

Etalon Theory

The equation for the transmission of an ideal etalon, an Airy Function, is

$$T = \left[1 + \frac{4R}{(1-R)^2} \sin^2 \left(\frac{\phi}{2} \right) \right]^{-1} \quad \phi = \frac{2\pi}{\lambda} 2nd \cos \theta$$

where
 T = transmission
 R = reflectivity of the mirrors
 ϕ = the roundtrip phase change of the light ray
 If any phase change at the mirror surfaces is ignored then

Where
 λ = the wavelength of the light
 n = the index of refraction of the material between the mirrors
 d = the distance between the mirrors
 θ = the angle of the incoming light beam

The above figure plots the etalon spectral transmission. The distance between adjacent peaks is the Free Spectral Range (D) and the width (FWHM) of each peak is the resolution (d). The Free Spectral Range can be written three ways:

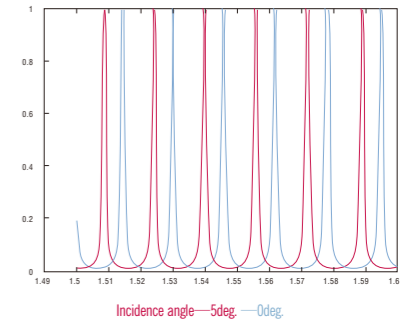

$$\Delta_\lambda(\text{frequency}) = \frac{c}{2nd} \quad \Delta_\lambda(\text{wavelength}) = \frac{\lambda^2}{2nd} \quad \Delta_\lambda(\text{wavenumbers}) = \frac{1}{2nd}$$

Another useful concept for etalons is the finesse (F). This dimensionless parameter is the ratio of the free spectral range to the peak width.

$$F = \frac{\Delta}{\delta} \quad \text{or} \quad \delta = \frac{\Delta}{F}$$

For an ideal etalon, only the mirror reflectivity determines the finesse.

$$F = F_R = \frac{\pi \sqrt{R}}{1-R}$$

Imperfections in the etalon such as not-perfect flatness and parallelism will degrade the finesse. Dayoptics includes the various imperfections into our etalon design calculations so we guarantee all quoted specifications.

Air Space Etalon

Air-Spaced Etalons have appropriate grade fused silica (UV-visible or IR) substrates. Outside-face AR coatings and wedges on the substrates prevent extraneous interference patterns from forming. Spacers, optically contacted to the substrates, determine the parallelism of the mirrored surfaces and the etalon's free spectral range. Depending upon the application, the spacers can be fused silica or a low thermal expansion material such as Zerodur or ULE.

Specifications

Plate Material	Fused Silica or Silicon(Si)
Spacer Material	Fused Silica, Zerodur, or ULE
Flatness	$\lambda / 20$
Parallelism	<1 arc sec
Gap	5m to 65mm
Clear Apertures	2mm to 100mm
Wavelengths	200nm to 3m
Finesse	Up to 100
Coatings	Standard and Custom

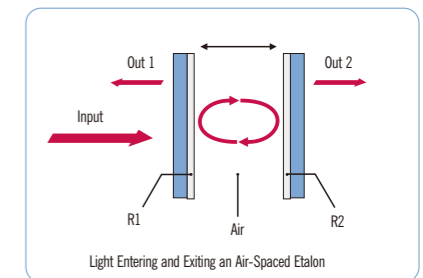

Solid Etalons

Solid Etalons typically have fused silica substrates with the material grade (e.g. UV-visible or IR) dependent on the spectral region. The faces are ground, polished, and figured typically to better than $\lambda / 100$ flatness with similar quality parallelism between the faces. Dielectric (or, rarely, metallic) coatings provide the reflectivity necessary for the required finesse.

Specifications

Material	Fused Silica
Flatness	< $\lambda / 20$
Parallelism	<1 arc sec
Clear Aperture	2mm to 125mm
Diameters	3mm to 150mm
Thickness	50m to 20mm
Wavelengths	200nm to 3m
Finesse	Up to 50
Coatings	Standard and Custom



Etalon Testing Instrument

LYOT DEPOLARIZER

Optical depolarizer is a kind of optical passive component which can transform the input polarized or partial polarized light into non-polarization light (depolarization), it is designed according to Lyot depolarizer's principle.

Dayoptics Lyot depolarizer consists of two crystalline plane parallel plates whose axes is 45° apart from each other with optical contacted. The thickness ratio of two plates length is typically 2:1. The depolarization is created by the superposition of the circularly, elliptically and linearly polarized light in different wavelengths. The depolarizer is not suitable for usage in monochromatic light.

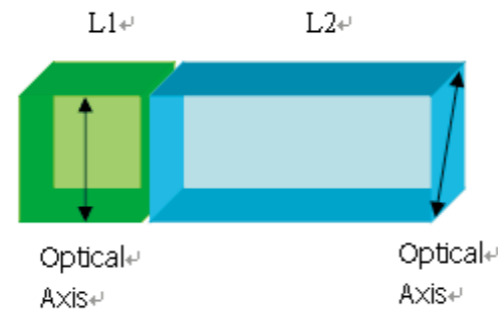

Theory Data

DOP - Degree of Polarization, DOP=1 good polarization, DOP=0 good depolarization

Material: Calcite

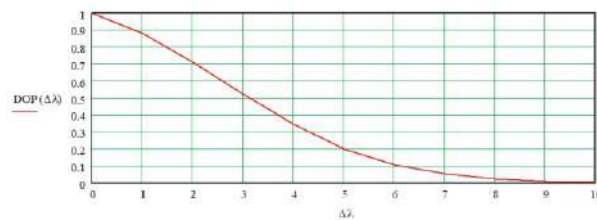

DOP Vs. wavelength bandwidth
Laser beam Wavelength is 1550nm, with total length of 6mm

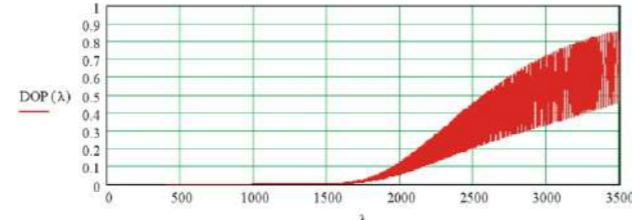

DOP Vs. input wavelength
(Input beam with 10nm bandwidth, total length 6mm)

Material: YVO4

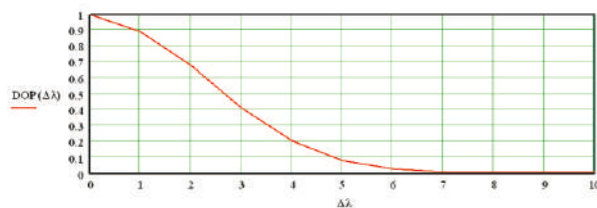

DOP vs. wavelength bandwidth
Laser beam Wavelength is 1550nm, with total length of 6mm

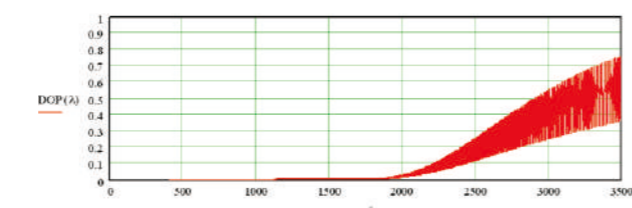

DOP Vs. input wavelength
(Input beam with 10nm bandwidth, total length 6mm)

Material: Quartz

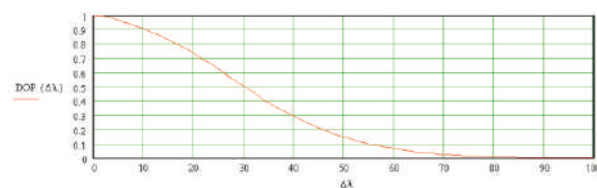

DOP Vs. wavelength bandwidth
Laser beam Wavelength is 1064nm, with total length of 6mm

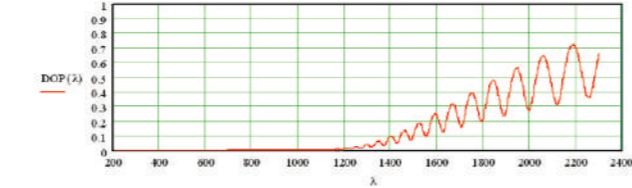

DOP Vs. input wavelength
(Input beam with 100nm bandwidth, total length 6mm)

LYOT DEPOLARIZER

Specifications

- Material: Calcite, YVO₄, Quartz
- Wavelength Range: Calcite: 350-2300nm, YVO₄: 500-4000nm, Quartz: 200-2300nm
- Dimension: +0/-0.2mm
- Parallelism: <20 arc second
- Flatness: λ/4 @633nm
- Surface Quality: 20/10 Scratch/Dig
- Surface contact method: Optical contact
- Coating is available upon requirement
- Mount is available upon requirement
- Total Length: 6mm



Part No	Material	Aperature	Total Length	Unit Price
DPL7005	CaCO ₃	5X5mm	6mm	\$180
DPL7010	CaCO ₃	10X10mm	6mm	\$250
DPL8005	YVO ₄	5X5mm	6mm	\$260
DPL8010	YVO ₄	10X10mm	6mm	\$320
DPL9005	Quartz	5X5mm	6mm	\$150
DPL9010	Quartz	10X10mm	6mm	\$220

E-O Q Switch BBO

BBO is one of the electro-optic material choices for high average power E-O Q Switch applications. BBO has significant advantages over other materials in terms of laser power handling abilities, temperature stability, and substantial freedom from piezoelectric ringing. Because it relies on the electro optic effect, switching time - aided by the low capacitance of the E-O Q Switch is very fast. The wide transparency range of BBO allows it to be used in diverse applications. E-O Q Switch of DEOB series are transverse field devices. Low electro-optical coefficient of BBO results in high operating voltages. The quarter-wave voltage is proportional to the ratio of electrode spacing and crystal length. As a result, a smaller aperture device has lower quarter-wave voltage. However, even for 3mm aperture devices quarter-wave voltage is as high as 3.4KV@1064nm. Double crystal design is employed in order to reduce required voltages and allowing operation in half-wave mode with fast switching times.

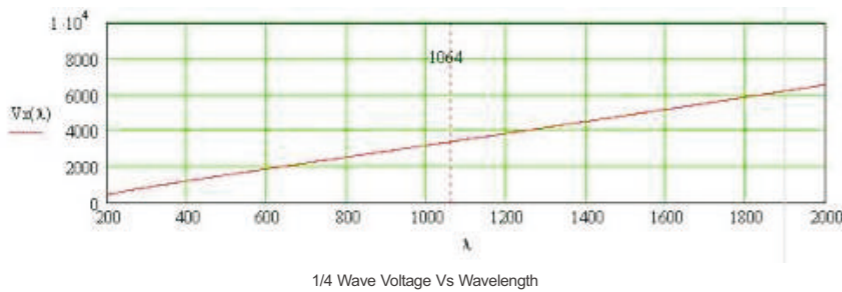

FEATURES:

- High Repetition Rate
- High peak power damage resistance
- Low absorption
- UV Transmission
- Low Acoustic Noise

Applications:

- High repetition rate DPSS Q-Switch
- High repetition rate Regenerative Amplifier control
- Cavity Dumping
- Beam Chopper

Specifications

Model Number	DEOB-254403
Aperture Diamete	2.5
Quarter-Wave Voltage@ 1064 nm	3.4KV
Optical Transmission	>98%
Damage Threshold	> 500 MW / cm ² @1064nm, 10ns
Wavefront Distortion@ 1064 nm	< λ /8
Typical Capacitance	< 3pf
Outline dimension, mm	φ 25.4 × 44

Description

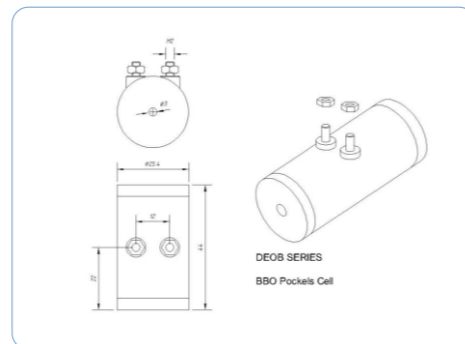

EO Q-SWITCHES-KD*P

A E-O Q Switch alters the polarization state of light passing through it when an applied voltage induces birefringence changes in an electro-optic crystal such as KD*P. When used in conjunction with polarizers, these cells can function as optical switches, or laser Q-switches. Our EO Q-switch employs the finest strain-free, highly deuterated KD*P available. Based on Dayoptics advanced crystal fabrication and coating technology, we can offer a variety of laser wavelengths EO Q switches which exhibits high transmission (T>97%), high damaged threshold (>500W/cm²) and high extinction ratio (>1000:1).

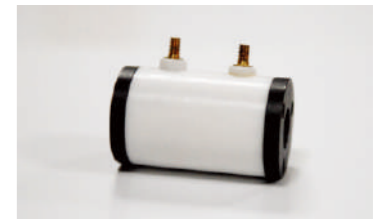

Applications

- OEM Laser Systems
- Medical/Cosmetic Lasers
- Versatile R&D Laser Platforms
- Military & Aerospace Laser Systems

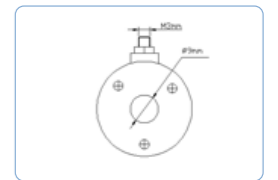
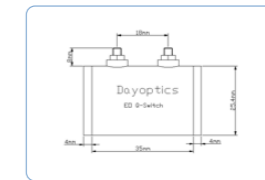

Features

- CCI Quality - Economically Priced
- Finest Strain-free KD*P
- Space Efficient
- Ceramic Apertures
- High Contrast Ratio
- Quick Electrical Connectors
- Ultra-flat Crystals

Benefits

- Exceptional Value
- High Contrast Ratio
- High Damage Threshold
- Low 1/2 Wave Voltage
- Ideal for Compact Lasers
- Clean and Highly Damage-resistant
- Exceptional Hold-off
- Efficient/Reliable Installation
- Excellent Beam Propagation

Electro-optical @ 1064nm

1/4 Wave Voltage	3.3 KV
Transmitted Wave Front Error	< 1/8 Wave
ICR	>2000:1
VCR	>1500:1
Capacitance	6 pf
AR @ 1064nm, 10ns pulse	5J/cm ²

Housing Dimensions	DEOQ-253508	DEOQ-253510	DEOQ-253513
Aperture	8 mm	10 mm	13 mm
Length	39 mm	39 mm	45 mm
Diameter	25.35 mm	25.35 mm	32 mm

Windows are applied to isolate different physical environments while allowing light to pass through. When selecting windows, it's impossible to consider materials, transmission, scattering, wavefront distortion, parallelism and resistance to certain environment. Dayoptics offers all kinds of windows, which are made from different materials. Windows of special sizes and materials are available upon requirement. Single layer or multiplayer anti-reflecting or high-reflecting coatings on optical windows are available upon customer's requirement.



Specification	BK7 Windows	Fused Silica Windows	Sapphire
Diameter Tolerance	+0.0, -0.1mm	+0.0, -0.1mm	+0.0, -0.2mm
Thickness Tolerance	±0.2mm	±0.2mm	±0.2mm
Clear Aperture	>80%	>80%	>85%
Parallelism	1'(Standard), 10"(High Precision)	1'(Standard), 10"(High Precision)	1'
Surface Quality	60/40(Standard), 20/10(High Precision)	60/40	60/40(Standard)
Wavefront Distortion	$\lambda / 4$ (Standard), $\lambda / 10$ (High Precision) per 25mm @633nm	$\lambda / 4$ (Standard), $\lambda / 10$ (High Precision) per 25mm @633nm	λ @ 633nm
Bevel	<0.25mm x 45°	<0.25mm x 45°	<0.25mm x 45°
Coating	Uncoated	Uncoated	Uncoated

Note: We can make coatings as your requires

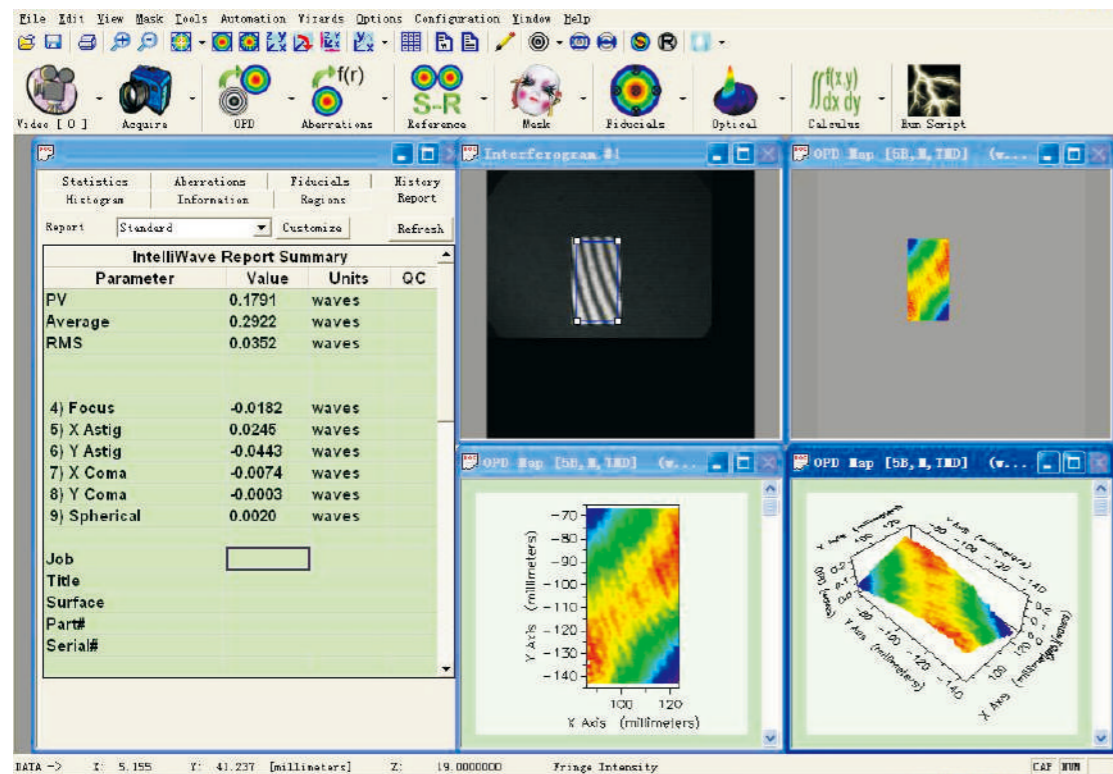

Standard Products

BK7 Windows		
Part No.	Diameter(mm)	Thickness(mm)
WIN0101	10.0	3.0
WIN0102	12.7	3.0
WIN0103	25.4	3.0
WIN0104	10.0	6.35
WIN0105	12.7	6.35
WIN0106	25.4	6.35

Fused Silica Windows		
Part No.	Diameter(mm)	Thickness(mm)
WIN0201	10.0	3.0
WIN0202	12.7	3.0
WIN0203	25.4	3.0
WIN0204	10.0	6.35
WIN0205	12.7	6.35
WIN0206	25.4	6.35

Sapphire Windows		
Part No.	Diameter(mm)	Thickness(mm)
WIN0301	5.5	0.5
WIN0302	8.5	0.5
WIN0303	9.5	0.5
WIN0304	10	1
WIN0305	12.7	1
WIN0306	25.4	1

Specifications

Material	BK7;Fused Silica
Diameter Tolerance	+0.0, -0.2mm
Thickness Tolerance	+/-0.1mm
Clear Aperture	>80%
Surface Figure	$\lambda/4@632.8\text{nm}$
Surface Quality	40/20 Scratch/Dig
Bevel	0.25 mm x 45°
Angle Tolerance	$\pm 3'$

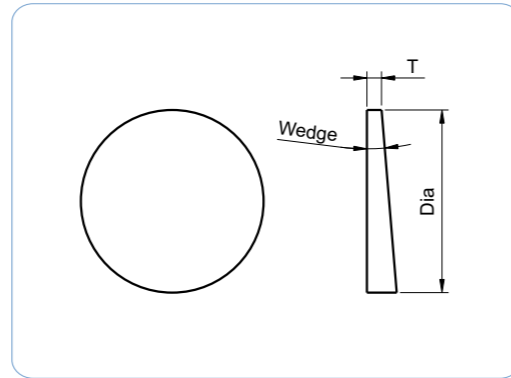

BK7 wedge

Part No.	Diameter (mm)	Thickness (mm)	Wedge (°)
WED1101	12.7	3.0	3.0
WED1201	12.7	3.0	0.5
WED1301	25.4	3.0	3.0
WED1401	25.4	3.0	0.5

Fused Silica wedge

Part No.	Diameter (mm)	Thickness (mm)	Wedge (°)
WED2101	12.7	6.35	3.0
WED2201	12.7	6.35	0.5
WED2301	25.4	6.35	3.0
WED2401	25.4	6.35	0.5

Filters are used for selecting or filtrating the specific wave band, they are widely used in optical instrument, industrial measurement, environment protection and many other applications. We can provides short pass filter, long pass filter, band pass filter, color glass filter, etc.

The dimension and coating index can be customized according to customer requirements.



Specifications

Material	BK7, Fused Silica, Color Glass
Dimension Tolerance	+0.0/-0.2
Parallelism	<3 arc minute
Surface Quality	60/40 Scratch/Dig
Clear Aperture	Central 90%
Flatness	$< \lambda @633\text{nm}$

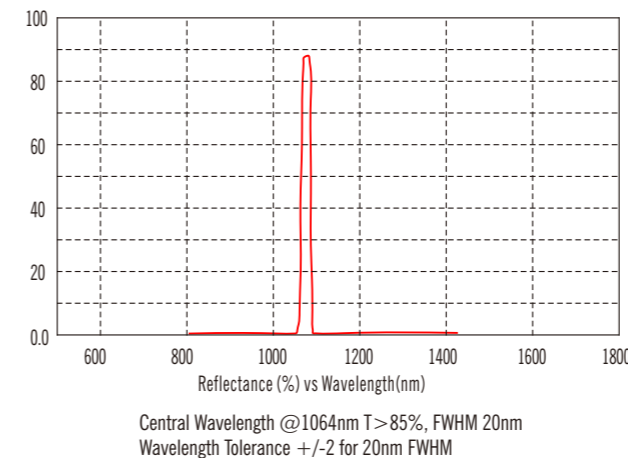
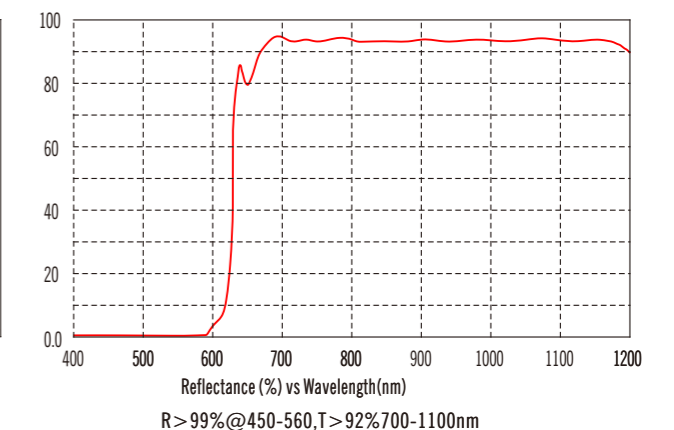
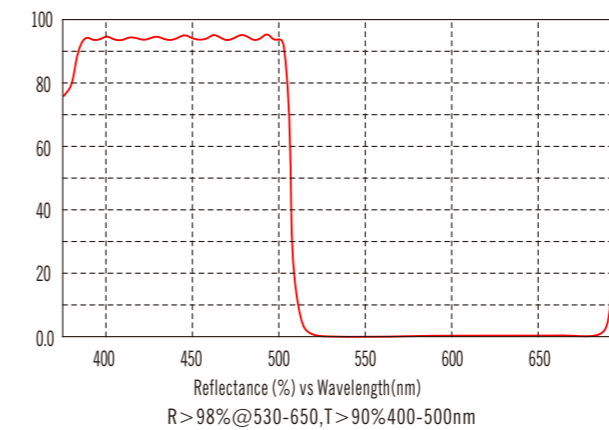
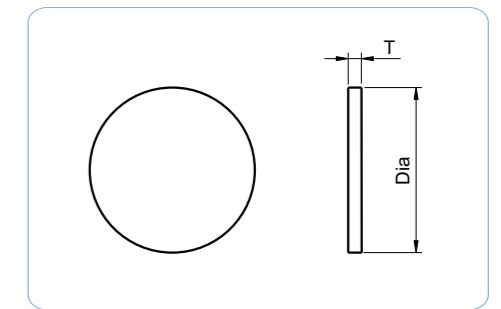

LENS OVERVIEW

A transparent optical component consisting of one or more pieces of optical glass with curved surfaces (usually spherical) that they serve to converge or diverge the transmitted rays from an object, thus forming a real or virtual image of that object. Dayoptics provides these lenses with the material of BK7, fused silica, sapphire, CaF₂ and MgF₂ as standard. Other materials lenses are available upon requirement.



Lens	Material	Illustration	Page
Plano Convex Cylindrical Lens	BK7 Fused Silica		49
Plano Concave Cylindrical Lens	BK7 Fused Silica		50
Cylindrical Positive Achromatic Lens	Depend on the design		51
C-Lens	Depend on the design		52
Plano Convex Lens	BK7 Fused Silica		53

LENS OVERVIEW

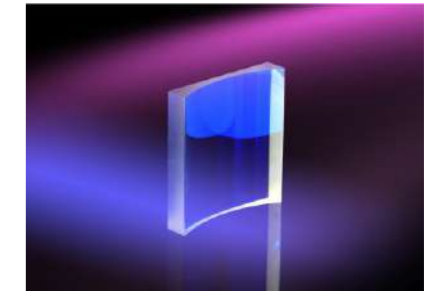

Lens	Material	Illustration	Page
Plano Concave Lens	BK7 Fused Silica		54
Double Convex Lens	BK7 Fused Silica		55
Double Concave Lens	BK7 Fused Silica		56
Achromatic Lens	Depend on the design		57
Ball Lens	BK7 Fused Silica		58

PLANO CONVEX CYLINDRICAL LENS

Specifications

Material	BK7;Fused Silica
Design Wavelength	589.6nm
Diameter Tolerance	+0.0, -0.15mm
Thickness Tolerance	+/-0.1mm
Paraxial Focal Length Tolerance	± 2%
Centration	3 arc minutes
Clear Aperture	>85%
Surface Figure	$\lambda/4@632.8\text{nm}$
Surface Quality	60/40 Scratch/Dig
Bevel	0.25 mm x 45°
Coating	Uncoated

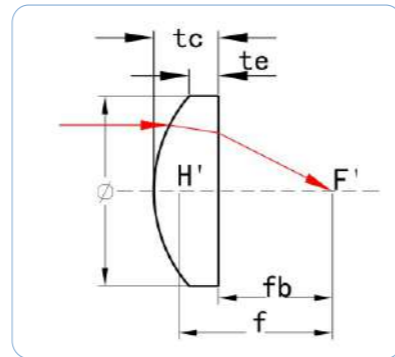
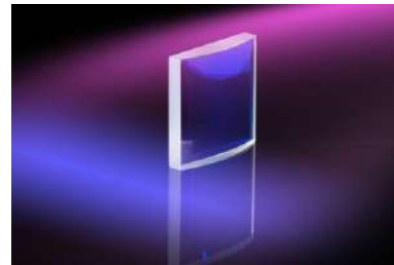

BK7/Fused Silica Plano Convex Cylindrical Lens

Part No	ϕ (mm)	f (mm)	R1 (mm)	t c (mm)	t e (mm)	f b (mm)	Material
PCYX1101	12.7	50	-25.8	3	2.2	48.02	BK7
PCYX1102	12.7	150	-77.4	3	2.74	148.02	BK7
PCYX1103	12.7	200	-103.2	3	2.8	198.02	BK7
PCYX2201	25.4	200	-91.6	3	2.11	197.942	Fused Silica
PCYX2202	25.4	300	-135	3	2.4	297.93	Fused Silica
PCYX2203	25.4	400	-180	3	2.55	397.93	Fused Silica
PCYX2301	10x10	25	-11.45	3	1.85	22.942	Fused Silica
PCYX2302	10x10	50	-22.9	3	2.447	47.942	Fused Silica
PCYX2401	20x20	100	-45.8	3	1.895	97.942	Fused Silica
PCYX2402	20x20	200	-91.6	3	2.453	197.942	Fused Silica

PLANO CONCAVE CYLINDRICAL LENS

Specifications

Material	BK7;Fused Silica
Design Wavelength	589.6nm
Diameter Tolerance	+0.0, -0.15mm
Thickness Tolerance	+/-0.1mm
Paraxial Focal Length Tolerance	± 2%
Centration	3 arc minutes
Clear Aperture	>85%
Surface Figure	$\lambda/4@632.8\text{nm}$
Surface Quality	60/40 Scratch/Dig
Bevel	0.25 mm x 45°
Coating	Uncoated

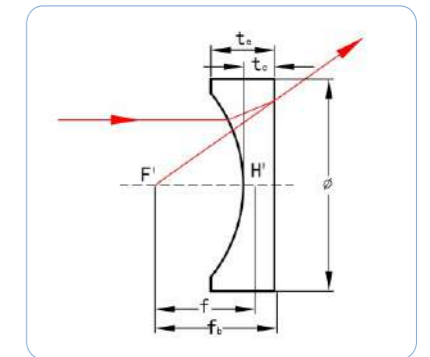
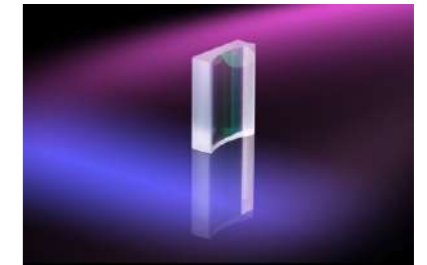

BK7/Fused Silica Plano Concave Cylindrical Lens

Part No	ϕ (mm)	f (mm)	R1 (mm)	t c (mm)	t e (mm)	f b (mm)	Material
PCW1101	12.5	-25	-12.9	2	3.62	-26.32	BK7
PCW1102	12.5	-40	-20.64	2	2.97	-41.32	BK7
PCW1103	12.5	-60	-30.96	2	2.64	-61.32	BK7
PCW2201	25.4	-100	-45.8	3	4.796	-102.058	Fused Silica
PCW2202	25.4	-200	-91.6	3	3.88	-202.058	Fused Silica
PCW2203	25.4	-300	-137.4	3	3.58	-302.058	Fused Silica
PCW2301	10x10	-25	-11.45	2	3.15	-26.372	Fused Silica
PCW2302	10x10	-40	-18.32	2	2.69	-41.372	Fused Silica
PCW2401	25x25	-600	-274.8	2	2.284	-601.372	Fused Silica
PCW2402	25x25	-800	-366.4	2	2.213	-801.372	Fused Silica

CYLINDRICAL POSITIVE ACHROMATIC LENSES

Specifications

Material	BK7,SF5
Design Wavelength	589.6nm
Diameter Tolerance	+0.0, -0.15mm
Thickness Tolerance	+/-0.1mm
Paraxial Focal Length Tolerance	± 2%
Centration	3 arc minutes
Clear Aperture	>85%
Surface Figure	$\lambda/4@632.8\text{nm}$
Surface Quality	60/40 Scratch/Dig
Bevel	0.25 mm x 45°
Coating	Uncoated

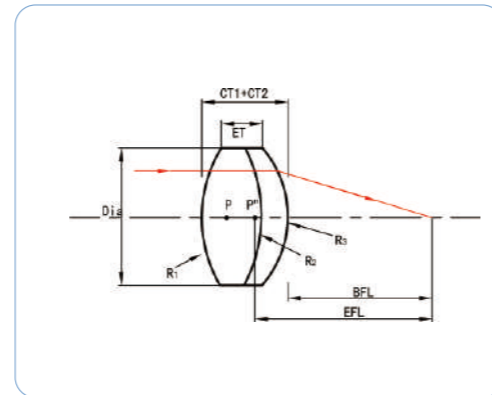

Positive Achromatic Lenses

Part No.	ϕ (mm)	f (mm)	R1(mm)	R2=R3(mm)	R4(mm)	CT1(mm)	CT2(mm)	fb(mm)	Lens A	Lens B
ALYP1301	12.5	25	10.55	10.55	200.14	7	2	18.32	BK7	SF5
ALYP1302	12.5	50	24.97	24.97	119.88	4	2	46.39	BK7	SF5
ALYP1303	12.5	75	38.1	38.1	172.49	3.5	2	71.79	BK7	SF5
ALYP1304	12.5	100	51.21	51.21	225.98	2	2	97.15	BK7	SF5

Fast-axis Collimation (Aspherical Cylindrical lenses)

The most important optical component in the beam forming systems in high-power diode lasers is the fast-axis-collimation optic. The lenses are manufactured from high-quality glass and have an aspherical surface. Their high numerical aperture permits the entire diode output to be collimated with outstanding beam quality. The high transmission and excellent collimation characteristics guarantee the highest levels of beam forming efficiency for diode lasers.

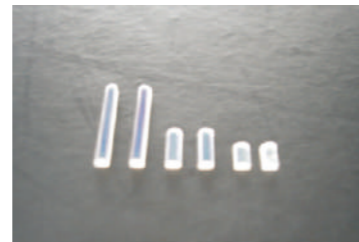

Advantages

- Aspheric cylindrical lens
- High beam quality
- High numerical aperture (NA 0.64-0.86)
- Diffraction-limited collimation
- High transmission
- Long term stability

Standard Specifications of Fast-axis Collimation

Part No	L(mm)	W(mm)	H(mm)	EFA(mm)	NA	WD(mm)	Coating
FAC0101	12	1.5	1.5	0.89	0.64	0.085	AR@808nm
FAC0201	5	1.6	1.22	0.9	0.86	0.228	AR@808nm
FAC0301	3	1.6	1.22	0.9	0.86	0.228	AR@808nm

C-LENS

Features

- Low Insertion Loss
- High precision

Applications

- Collimators
- Isolators
- Switches
- Collimator Array
- Laser Assembly



Specifications

Diameter tolerance	+0.005/-0.01mm
Length Tolerance	+/-0.04mm
Surface Quality	20/10 Scratch/Dig
Damage Threshold	>600MW
Coating	R<0.25%@1550±40nm

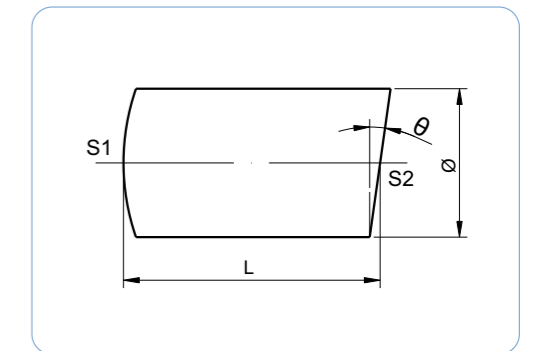

Part No	θ (Heg)	ϕ (mm)	Central Wavelength(nm)	L (mm)
CLS0101	8	1.0	1550	2.62
CLS0102	8	1.8	1550	2.94
CLS0103	8	1.8	1310	3.85
CLS0104	8	1.8	1550	3.85
CLS0105	8	1.8	1550	6.61

PLANO CONVEX LENS

Specifications

Material	BK7
Design Wavelength	546.1nm
Design Index	1.5183 ± 0.0005
Diameter Tolerance	+0.0, -0.15mm
Paraxial Focal Length Tolerance	± 2%
Centration	3 arc minutes
Clear Aperture	> 85%
Surface Figure	$\lambda/4@632.8\text{nm}$
Surface Quality	60/40 Scratch/Dig
Bevel	0.25 mm x 45°
Coating	Uncoated

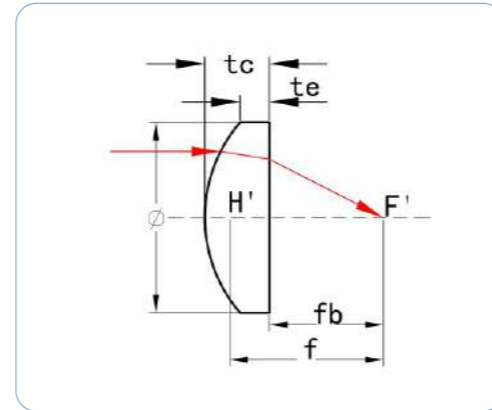

BK7 Plano Convex Lens

Part No	ϕ (mm)	f (mm)	R1 (mm)	t c (mm)	t e (mm)	f b (mm)
PCX1201	12.7	15	7.78	5.3	2	11.5
PCX1202	12.7	20	10.37	4.2	2	17.2
PCX1203	12.7	25	12.96	3.7	2	22.6
PCX1204	12.7	30	15.55	3.4	2	27.8
PCX1205	12.7	40	20.73	3	2	38
PCX1206	12.7	50	25.92	2.8	2	48.2
PCX1207	20	35	18.155	4.2	1.2	32.2
PCX1208	20	40	20.73	4.5	1.9	37
PCX1209	20	50	25.936	4	2	47.4
PCX1303	25.4	50	25.92	5.3	2	46.5
PCX1309	25.4	60	31.1	4.7	2	56.9
PCX1304	25.4	75	38.87	4.1	2	72.3
PCX1305	25.4	100	51.83	3.6	2	97.6
PCX1306	25.4	125	64.79	3.3	2	122.8
PCX1307	25.4	150	77.75	3	2	148
PCX1308	25.4	200	103.66	2.8	2	198.2

PLANO CONCAVE LENS

Specifications

Material	BK7
Design Wavelength	546.1nm
Design Index	1.5183 ± 0.0005
Diameter Tolerance	+0.0, -0.15mm
Paraxial Focal Length Tolerance	± 2%
Centration	3 arc minutes
Clear Aperture	> 85%
Surface Figure	$\lambda/4@632.8\text{nm}$
Surface Quality	60/40 Scratch/Dig
Bevel	0.25 mm x 45°
Coating	Uncoated

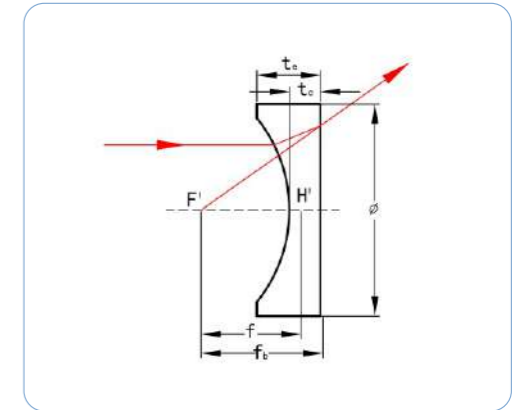

BK7 Plano Concave Lens

Part No.	ϕ (mm)	f (mm)	R1 (mm)	t c (mm)	t e (mm)	f b (mm)
PCV1201	12.7	-15	-7.78	2	5.3	-16.3
PCV1202	12.7	-20	-10.37	2	4.1	-21.3
PCV1203	12.7	-25	-12.96	2	3.7	-26.3
PCV1204	12.7	-30	-15.55	2	3.4	-31.3
PCV1205	12.7	-40	-20.73	2	3	-41.3
PCV1206	12.7	-50	-25.92	2	2.8	-51.3
PCV1301	25.4	-25	-12.97	2	10.9	-26.3
PCV1302	25.4	-35	-18.14	2	7.2	-36.3
PCV1303	25.4	-50	-25.92	2	5.3	-51.3
PCV1305	25.4	-75	-38.87	2	4.1	-76.3
PCV1306	25.4	-100	-51.83	2	3.6	-101.3
PCV1307	25.4	-150	-77.75	2	3	-151.3
PCV1308	25.4	-200	-103.66	2	2.7	-201.3

DOUBLE CONVEX LENS

Specifications

Material	BK7
Design Wavelength	546.1nm
Design Index	1.5183 ± 0.0005
Diameter Tolerance	+0.0, -0.15mm
Paraxial Focal Length Tolerance	± 2%
Centration	3 arc minutes
Clear Aperture	>85%
Surface Figure	$\lambda/4@632.8\text{nm}$
Surface Quality	60/40 Scratch/Dig
Bevel	0.25 mm x 45°
Coating	Uncoated

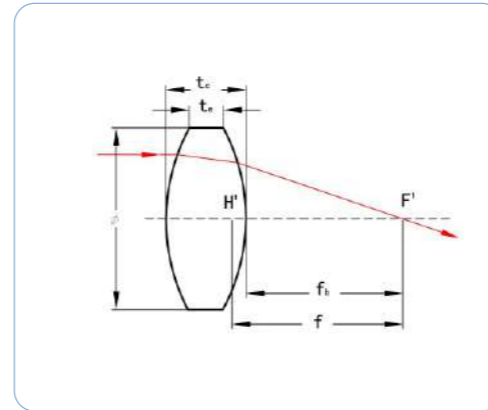

Part No.	ϕ (mm)	f (mm)	R1 (mm)	t c (mm)	t e (mm)	f b (mm)
DCX1201	12.7	20	20.01	4	2	18.6
DCX1202	12.7	25	25.28	3.6	2	23.8
DCX1203	12.7	30	30.52	3.3	2	28.9
DCX1204	12.7	40	40.95	3	2	39
DCX1301	25.4	25.4	24.71	9	2	22.2
DCX1314	25.4	35	35.09	6.8	2	32.8
DCX1315	25.4	40	40.4	6.1	2	37.9
DCX1302	25.4	50	50.92	5.2	2	48.3
DCX1316	25.4	60	61.4	4.7	2	58.5
DCX1303	25.4	75	77.04	4.1	2	73.6
DCX1304	25.4	100	103.05	3.6	2	98.8
DCX1305	25.4	125	129.02	3.3	2	123.9
DCX1306	25.4	150	154.97	3	2	149
DCX1307	25.4	200	206.84	2.8	2	199
DCX1308	25.4	250	258.7	2.6	2	249.1
DCX1309	25.4	300	310.55	2.5	2	299.2
DCX1310	25.4	400	413.8	2.4	2	399
DCX1311	25.4	500	517.91	2.3	2	499.2
DCX1312	25.4	750	774.3	2.3	2	748.8
DCX1313	25.4	1000	1036.23	2.2	2	999.3

DOUBLE CONCAVE LENS

Specifications

Material	BK7
Design Wavelength	546.1nm
Design Index	1.5183 ± 0.0005
Diameter Tolerance	+0.0, -0.15mm
Paraxial Focal Length Tolerance	± 2%
Centration	3 arc minutes
Clear Aperture	>85%
Surface Figure	$\lambda/4@632.8\text{nm}$
Surface Quality	60/40 Scratch/Dig
Bevel	0.25 mm x 45°
Coating	Uncoated

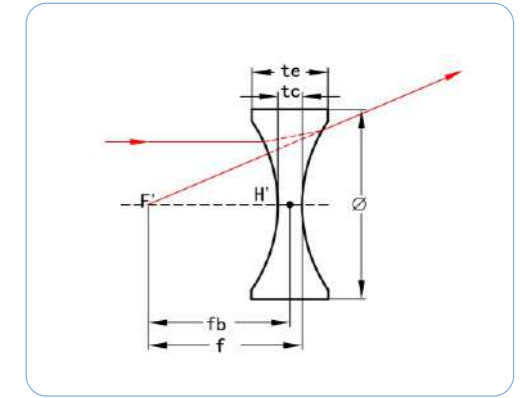

Part No.	ϕ (mm)	f (mm)	R1 (mm)	t c (mm)	t e (mm)	f b (mm)
DCV1201	12.7	-25	26.25	2	3.6	-25.7
DCV1202	12.7	-30	31.44	2	3.3	-30.7
DCV1203	12.7	-40	41.8	2	3	-40.7
DCV1204	12.7	-50	52.17	2	2.8	-50.7
DCV1301	25	-25	26.25	2	8.6	-25.7
DCV1302	25.4	-35	36.62	2	6.5	-35.7
DCV1303	25.4	-50	52.17	2	5.1	-50.7
DCV1305	25.4	-75	78.09	2	4.1	-75.7
DCV1306	25.4	-100	104	2	3.6	-100.7

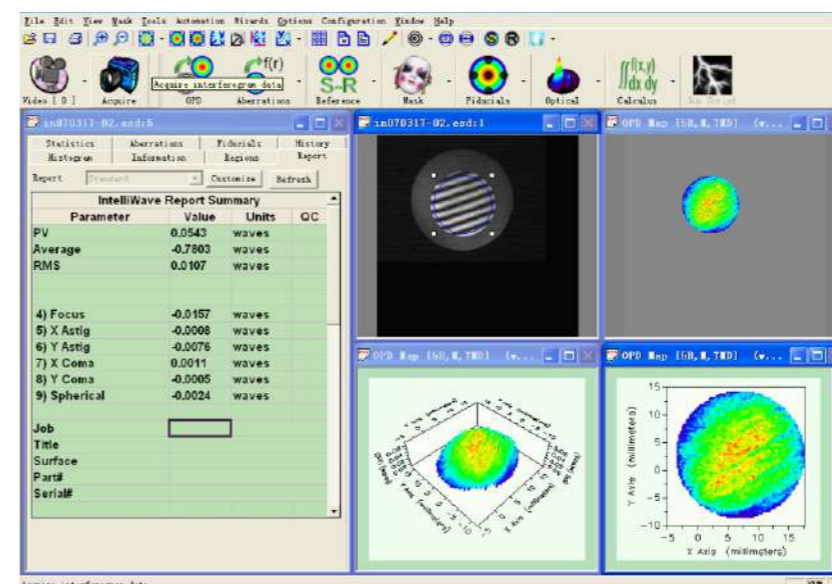

ACHROMATIC LENSES

Specifications

Design Wavelength	480.0, 546.1, 643.8nm
Diameter Tolerance	+0.0, -0.15mm
Paraxial Focal Length Tolerance	± 2%
Centration	3 arc minutes
Clear Aperture	>85%
Surface Figure	$\lambda/4@632.8\text{nm}$
Surface Quality	60/40 Scratch/Dig
Bevel	< 0.25 mm x 45°
Coating	$\lambda/4$ Wave $\text{MgF}_2@550\text{nm}$

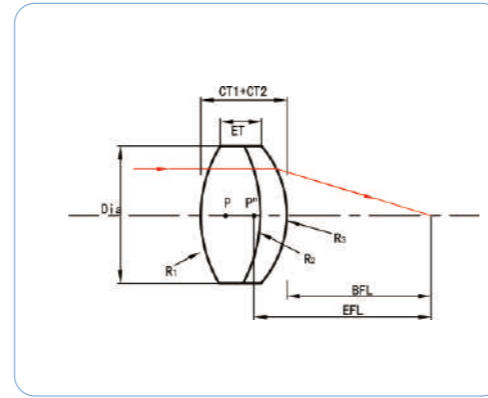

Positive Achromatic Lenses

Part No.	ϕ (mm)	f (mm)	R1(mm)	R2=R3(mm)	R4(mm)	CT1(mm)	CT2(mm)	fb(mm)	Lens A	Lens B
ALP0101	6	15	8.831	-6.546	-19.77	2.71	1	13.066	BK7	SF5
ALP0102	6	20	12.356	-8.511	-24.38	2.6	1	18.288	BK7	SF5
ALP0103	6	25	15.704	-10.666	-29.99	2.3	1	23.455	BK7	SF5
ALP0104	6	30	18.88	-12.942	-36.48	1.9	1	28.695	BK7	SF5
ALP0105	8	25	15.596	-10.814	-30.48	2.9	1	23.125	BK7	SF5
ALP0106	8	30	18.88	-12.882	-36.22	2.7	1	28.277	BK7	SF5
ALP0107	10	20	12.3	-9.02	-25.23	3.6	1	17.625	BK7	SF5
ALP0201	12	25	15.346	-11.35	-31.92	4.2	1.3	22.286	BK7	SF5
ALP0202	12.7	25	15.596	-11.402	-31.05	4.3	1.3	22.251	BK7	SF5
ALP0203	12.7	30	18.535	-13.49	-37.84	4	1.3	27.36	BK7	SF5
ALP0204	12.7	40	25.23	-17.539	-48.75	3.4	1.3	37.778	BK7	SF5
ALP0205	12.7	50	31.26	-21.93	-62.37	3.1	1.3	47.992	BK7	SF5
ALP0206	12.7	60	37.33	-26.42	-75.86	2.8	1.3	58.127	BK7	SF5
ALP0207	12.7	75	46.77	-32.96	-94.62	2.6	1.3	73.227	BK7	SF5
ALP0208	20	65	40.09	-29.58	-83.59	6.3	2	60.868	BK7	SF5
ALP0301	25.4	60	37.33	-27.16	-75.86	7	2	55.565	BK7	SF5
ALP0302	25.4	120	73.28	-54.33	-159.96	4.2	2	117.103	BK7	SF5

Negative Achromatic Lenses

Part No.	ϕ (mm)	f (mm)	R1(mm)	R2=R3(mm)	R4(mm)	CT1(mm)	CT2(mm)	fb(mm)	Lens A	Lens B
ALN0201	12.7	-25	-15.6	13.09	44.16	3	2.67	-27.5	BK7	F2
ALN0202	12.7	-40	-24.45	17.97	66.6	3	2.34	-42.5	BK7	F2
ALN0301	25.4	-50	-31.19	24.89	85.31	3	4.22	-53.3	BK7	F2

BALL LENS

Product Overview

Ball lenses are near perfect polished spheres of glass or other transparent materials used to focus light from laser sources into fibers and to couple light from fiber to fiber by matching the N.A.(numerical aperture) of the balls to the fibers. Balls can be machined into drums for higher fiber array pitch and mounting alignment accuracy.

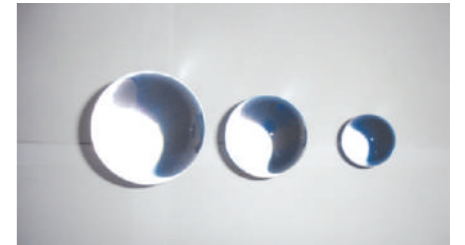

Specifications

Material	BK7 and other optical glass
Diameter tolerance	+0/-0.005mm
Sphericity	+/-0.001mm
Surface quality	40/20
Surface quality	<2.5 lambda

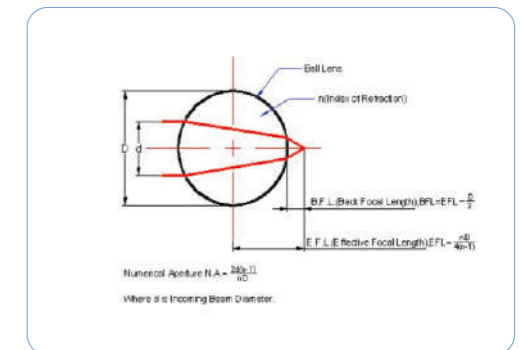

Part No	Diameter (mm)	Dia tolerance(mm)	Sphericity(mm)	Surface quality
BAL0010	1.0	+/-0.005	+/-0.002	40/20
BAL0030	3.0	+/-0.005	+/-0.002	40/20
BAL0040	4.0	+/-0.005	+/-0.002	40/20
BAL0050	5.0	+/-0.005	+/-0.002	40/20

PRISM OVERVIEW

Prism	Illustration	Material	Angle Precision	Application
Penta Prism		BK7	1 Min. Deviation 30 Sec. Deviation 10Sec. Deviation	Plumb Level, Surveying, Alignment, Range Finding and Optical Tooling
Beamsplitter Penta Prism		BK7	1 Min. Deviation 30 Sec. Deviation 10Sec. Deviation Transmission/Reflection:20/80 ± 5 or 50/50 ± 5	Plumb Level, Surveying, Alignment, Range Finding and Optical Tooling
Corner Cube Retroreflectors		BK7	3 Sec. Deviation 5 Sec. Deviation	Plumb Level, Surveying, Alignment, Range Finding and Optical Tooling
Right Angle Prism		BK7 Fused Silica	3 Min. Deviation 1 Min. Deviation 30 Sec. Deviation 10 Sec. Deviation 5 Sec. Deviation	Plumb Level, Surveying, Alignment, Range Finding and Optical Tooling
Anamorphic Prism		SF11	30 Sec. Deviation	For Beam Expansion
Dove Prism		BK7	3 Min. Deviation	Medical Instrument, Optical Tooling and Other Optical Systems
Roof Prism		BK7	3 Sec. Deviation 5 Sec. Deviation	Medical Instrument, Optical Tooling and Other Optical Systems
Rhomboid Prism		BK7	3 Min. Deviation 1 Min. Deviation 30 Sec. Deviation 10 Sec. Deviation 5 Sec. Deviation	Plumb Level, Surveying, Alignment, Range Finding and Optical Tooling

PENTA PRISM

Penta prism can deviate an incident beam without inverting or reversing 90°. The deviation angle of 90° is independent of any rotation of the prism about an axis parallel to the line of intersection of the two reflecting faces. It is commonly used in plumb level, surveying, alignment, range finding and optical tooling. The reflecting surfaces of this Prism must be coated with a metallic or dielectric coating. The standard Penta Prism reflecting surfaces are coated with aluminum or enhanced aluminum.

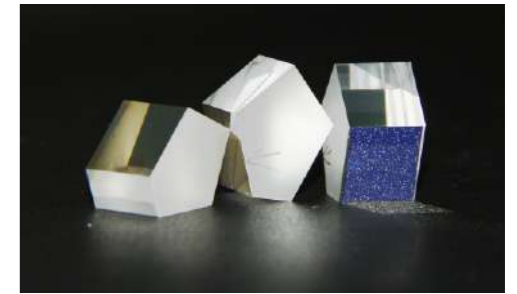

Specifications

Material	BK7 Grade A Optical Glass
Dimension Tolerance	± 0.2mm
90° Deviation Tolerance	According to the Table
Flatness	$\lambda/2$ (Standard), $\lambda/4$ (High Precision)@633nm
Reflectivity	R > 95% per Face @400~700 nm
Surface Quality	60/40 Scratch/Dig
Coating on Input and Output Surface	Uncoated

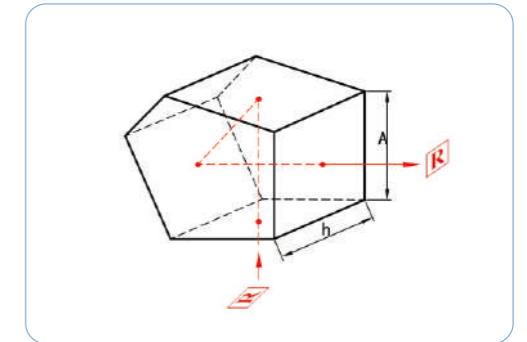

Size(mm)	1 min. Deviation	30 Sec. Deviation	10Sec. Deviation
A x h	Part No.	Part No.	Part No.
2.5 x 2.5	PTP1101	PTP1201	PTP1301
7 x 5	PTP1102	PTP1202	PTP1302
7 x 6	PTP1103	PTP1203	PTP1303
10 x 10	PTP1104	PTP1204	PTP1304
15 x 15	PTP1105	PTP1205	PTP1305
20 x 20	PTP1106	PTP1206	PTP1306

BEAMSPLITTER PENTA PRISM & CORNER CUBE RETROREFLECTOR

Beamsplitter Penta Prism

By adding a wedge and with partial reflective coating on first reflective surface, Penta Prism can be used as Beamsplitter. We supply Beamsplitter Penta Prism with standard Transmission/reflection (T/R) ratio of 20/80, 50/50. Other T/R ratio is available upon request.

Specifications

Material	BK7 Grade A Optical Glass
Dimension Tolerance	±0.2 mm
90° Deviation Tolerance	According to the Form
Flatness	$\lambda/2$ (Standard), $\lambda/4$ (High Precision)@633nm
Reflectivity	R>95% Per Face @400~700nm
Surface Quality	60/40 Scratch/Dig
Beamsplitter Ratio Transmission/Reflection	20/80 ± 5 or 50/50 ± 5
Coating on Input and Output Surface	Uncoated

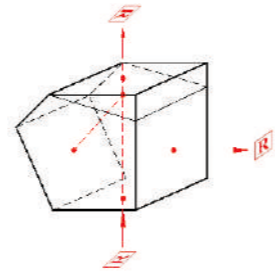

Size(mm)	1 min. Deviation	30 Sec. Deviation	10Sec. Deviation
A x h	Part No.	Part No.	Part No.
7 x 6	PPS1103	PPS1203	PPS1303
10 x 10	PPS1104	PPS1204	PPS1304
15 x 15	PPS1105	PPS1205	PPS1305
20 x 20	PPS1106	PPS1206	PPS1306

Corner Cube Retroreflectors

Specifications

Material	Bk7 Grade A Optical Glass
Dimension Tolerance	+0.0, -0.2 mm
Clear Aperture	>80%
Deviation	180° ± 3"
Flatness	$\lambda/4$ on big surface, $\lambda/10$ on Other Surfaces
Surface Quality	60/40 Scratch and Dig
Wavefront Distortion	$\lambda/2$ @633nm
Bevel	0.2 mm to 0.5 mm
Coating on Input and Output Surface	Uncoated

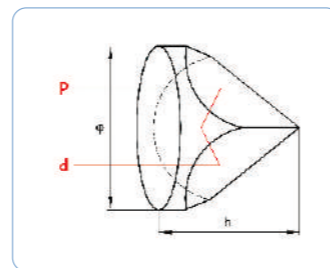

Part No.	φ (mm)	h(mm)
CCR1101	15	11.3
CCR1102	25.4	19
CCR1103	38.1	29.2
CCR1104	50.8	38.1

RIGHT ANGLE PRISM & ANAMORPHIC

Specifications

Material	BK7 Grade A Optical Glass
Dimension Tolerance	+0.0, -0.2 mm
Clear Aperture	>80%
Angle Tolerance	See the Table
Flatness	$\lambda/2$ @633 nm
Surface Quality	60/40 Scratch/Dig
Bevel	0.2 mm to 0.5 mm
Coating	Uncoated

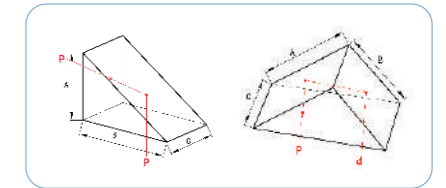
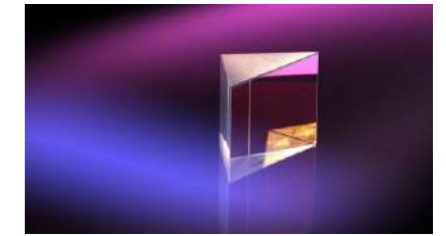

High precision RAP: high angle precision(<5 second), high flatness(<lambda/10), high angle pyramid tolerance (<5 second) are available upon requirement.

Size(mm)	3 min. Deviation	1 min. Deviation	30Sec. Deviation
A,B,C	Part No.	Part No.	Part No.
A=B=C=2.0	RAP1101	RAP1201	RAP1301
A=B=C=3.2	RAP1102	RAP1202	RAP1302
A=B=C=5.0	RAP1103	RAP1203	RAP1303
A=B=C=10.0	RAP1104	RAP1204	RAP1304
A=B=C=12.7	RAP1105	RAP1205	RAP1305
A=B=C=15.0	RAP1106	RAP1206	RAP1306
A=B=C=20.0	RAP1107	RAP1207	RAP1307
A=B=C=25.4	RAP1108	RAP1208	RAP1308
A=B=C=30.0	RAP1109	RAP1209	RAP1309

Anamorphic Prisms

Specifications

Material	SF11 Grade A Optical Glass
Dimension Tolerance	+0.0, -0.2 mm
Clear Aperture	>80%
Flatness	$\lambda/8$ @633 nm
Theta	$\theta = 29^\circ 27' \pm 3''$
Surface Quality	60/40 Scratch/Dig
Coating	MgF2 Single Layer on Perpendicular Surface

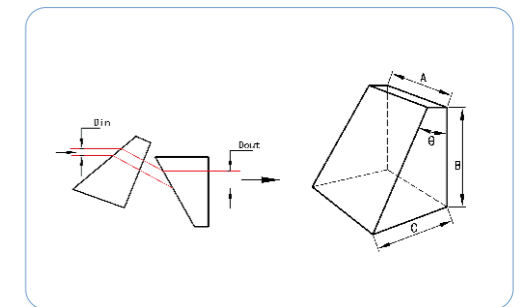

Part No.	A (mm)	B (mm)	C (mm)
ANP0101	12	12	8.5

DOVE PRISM

Specifications

Material	BK7 Grade A Optical Glass
Dimension Tolerance	+0.0, -0.2 mm
Clear Aperture	>80%
Angle Tolerance	± 3 arc minutes
Flatness	$\lambda/2$ @633 nm
Surface Quality	60/40 Scratch/Dig
Bevel	0.2 mm to 0.5 mm
Coating	Uncoated

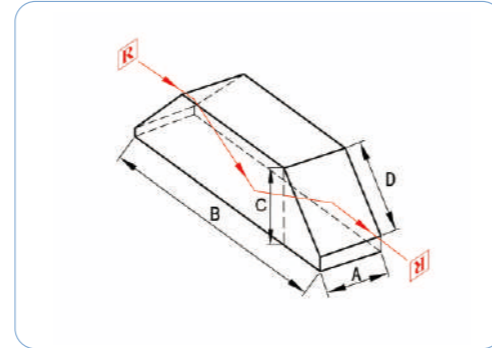

Part No.	A (mm)	B (mm)	C (mm)
DOP1101	5	21.1	5
DOP1102	10	42	10
DOP1103	15	64	15

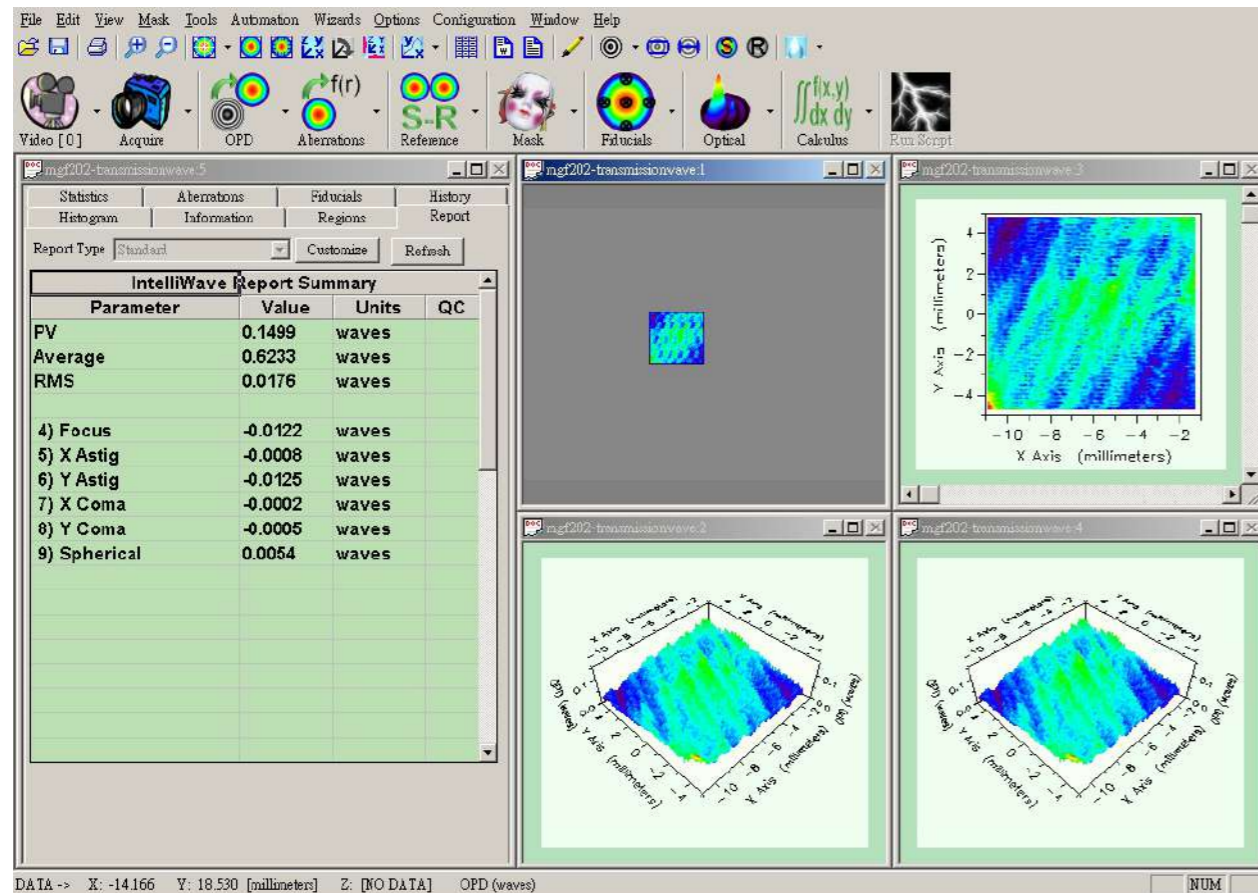

DATA -> X: -14.166 Y: 18.530 [millimeters] Z: [NO DATA] OPD (waves) NUM

ROOF PRISM & RHOMBOID PRISM

Specifications

Material	BK7 or Fused Silica
Dimension Tolerance	+/-0.1 mm
Clear Aperture	>80%
Angle Tolerance	± 30 arc sec
Flatness	$\lambda/4$ @633 nm
Surface Quality	60/40 Scratch/Dig
Bevel	0.2 mm to 0.5 mm

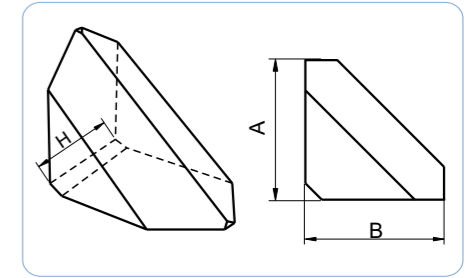
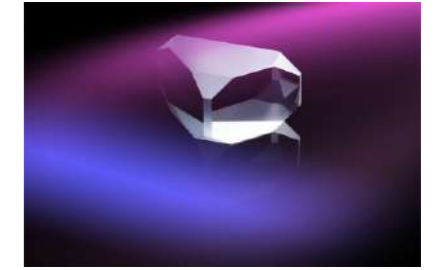

Part No.	A (mm)	B (mm)	H (mm)
RFP1101	15.0	15.0	12.0
RFP1102	23.0	23.0	18.0
RFP1103	31.5	31.5	23.0

Rhomboid Prisms

Specifications

Material	BK7 Grade A Optical Glass
Dimension Tolerance	+0.0/-0.2 mm
Clear Aperture	>80%
Angle Tolerance	3' (3" can be available)
Flatness	$\lambda/4$ @633 nm
Surface Quality	60/40 Scratch/Dig (20/10 can be available)
Bevel	0.2 mm to 0.5 mm

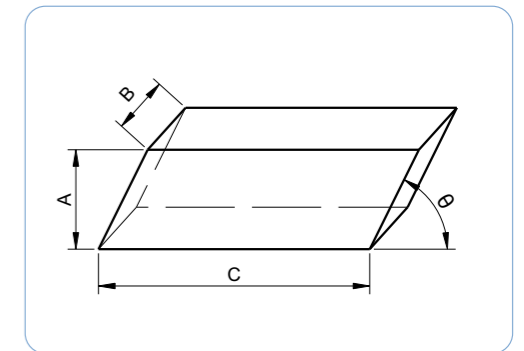

Part No.	A (mm)	B (mm)	C (mm)	θ
RHP1101	3.5	3.5	6.3	45°
RHP1102	10.0	10.0	14.2	45°
RHP1103	15.0	15.0	21.2	45°

ANTI-REFLECTIVE COATING

A thin layer of material applied to a surface to reduce the amount of reflected energy. Ideally the index of refraction of that material should be equal to the square root of the product of the indices of the material on either side of the coating, while the ideal thickness for a single-layer coating is one-quarter of the wavelength at which reflectance is to be minimized.

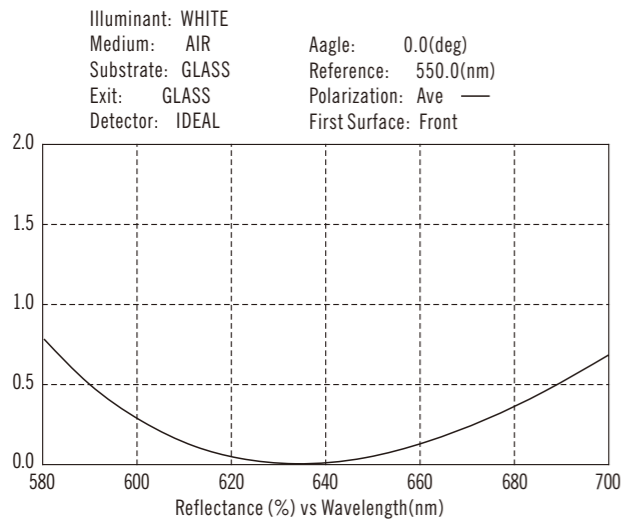

AR@633nm

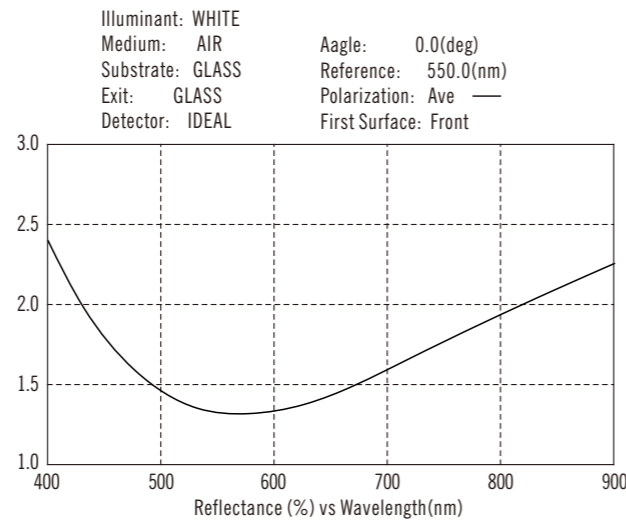

MgF2@550nm

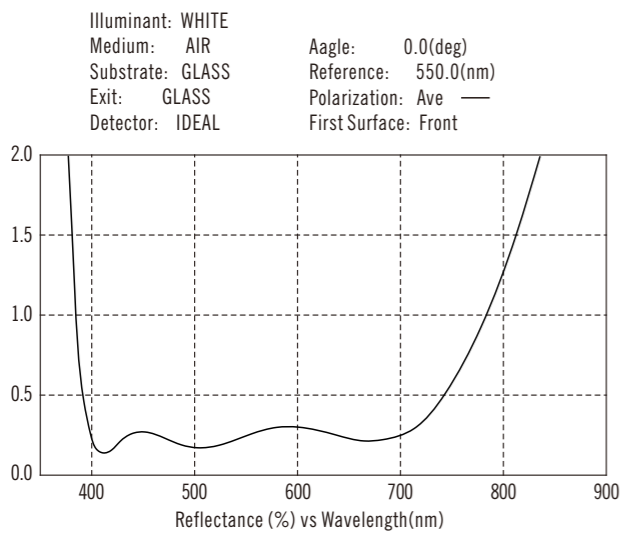

AR@400-700nm

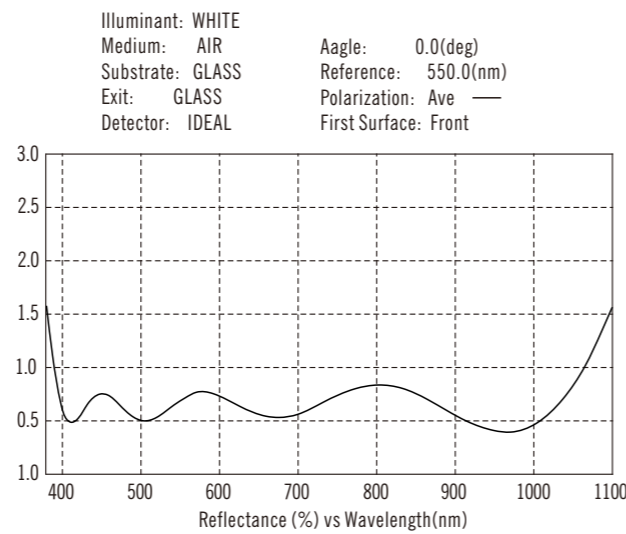

AR@400-1000nm

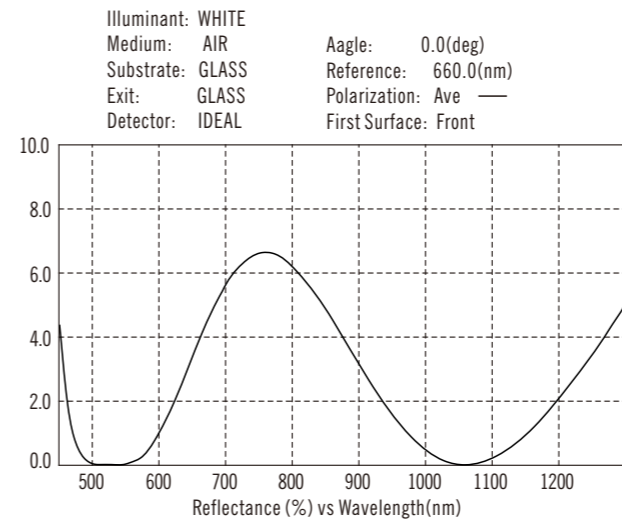

AR@532&1064nm

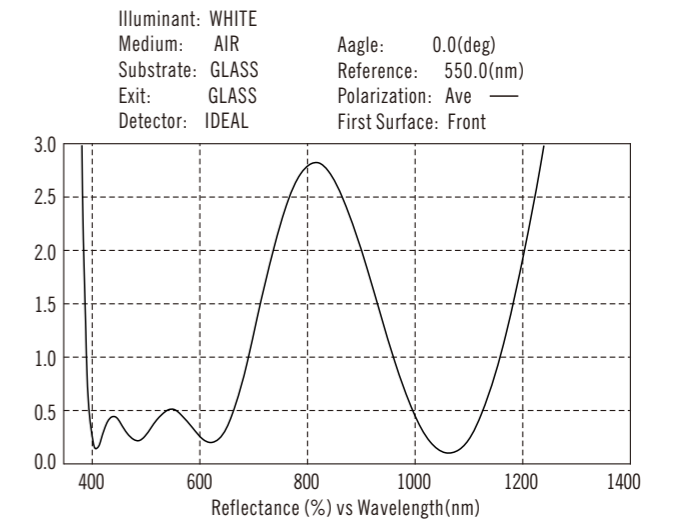

AR@400-600&1064nm

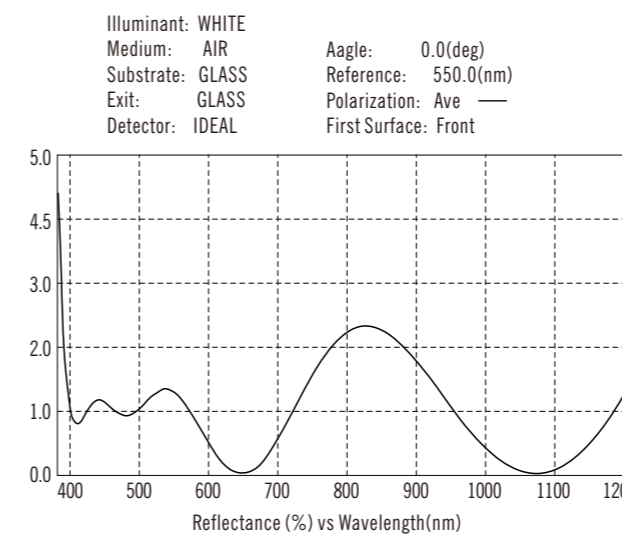

AR@400-1200nm

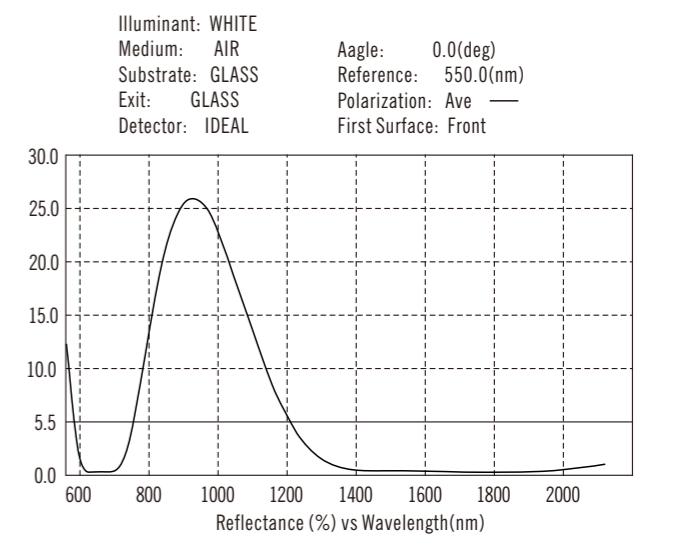

AR@650&1400-2000nm

ANTI-REFLECTIVE COATING

A thin layer of material applied to a surface to reduce the amount of reflected energy. Ideally the index of refraction of that material should be equal to the square root of the product of the indices of the material on either side of the coating, while the ideal thickness for a single-layer coating is one-quarter of the wavelength at which reflectance is to be minimized.

DIELECTRIC COATING- HR COATING AND PR COATING

A dielectric coating consisting of alternating layers of quarter-wave film of a higher refractive index and lower refractive index than the substrate. Such coatings can be made very specific to a reflected wavelength or, by varying the layers' thicknesses or film indexes, spread over a wide wavelength interval including high reflection coating (HR) and partial reflective coating (PR).

Illuminant: WHITE
 Medium: AIR
 Substrate: GLASS
 Exit: GLASS
 Detector: IDEAL
 Angle: 45.0(deg)
 Reference: 800.0(nm)
 Polarization: Ave
 First Surface: Front

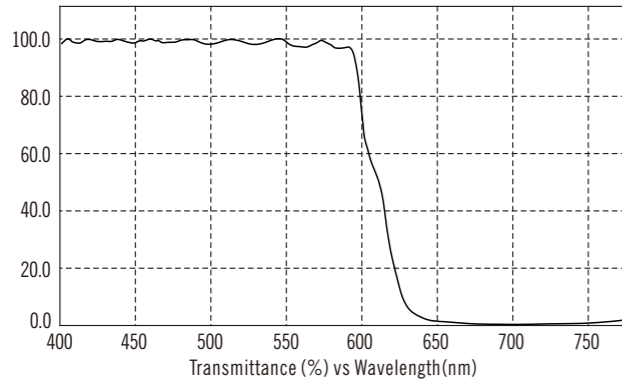

HT@400-560nm&HR@650-750nm AOI=45°

Illuminant: WHITE
 Medium: AIR
 Substrate: GLASS
 Exit: GLASS
 Detector: IDEAL
 Angle: 0.0(deg)
 Reference: 550.0(nm)
 Polarization: Ave
 First Surface: Front

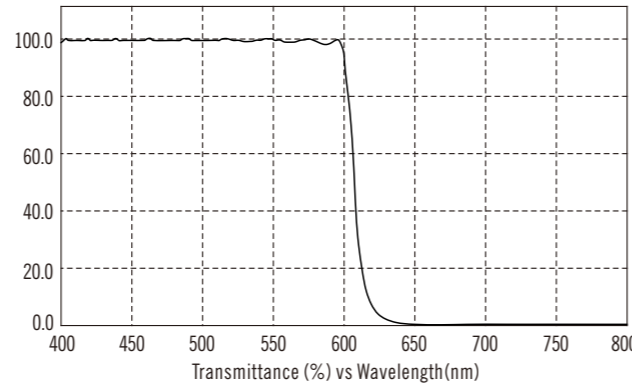

HT@400-560nm&HR@650-750nm AOI=0°

Illuminant: WHITE
 Medium: AIR
 Substrate: GLASS
 Exit: GLASS
 Detector: IDEAL
 Angle: 0.0(deg)
 Reference: 550.0(nm)
 Polarization: Ave
 First Surface: Front

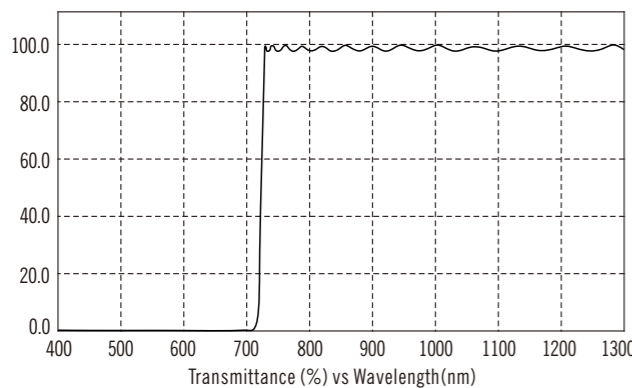

HR@400-700nm&HT@730-815nm AOI=0°

Illuminant: WHITE
 Medium: AIR
 Substrate: GLASS
 Exit: GLASS
 Detector: IDEAL
 Angle: 45.0(deg)
 Reference: 630.0(nm)
 Polarization: Ave
 First Surface: Front
 X:406.3 Y:70.7

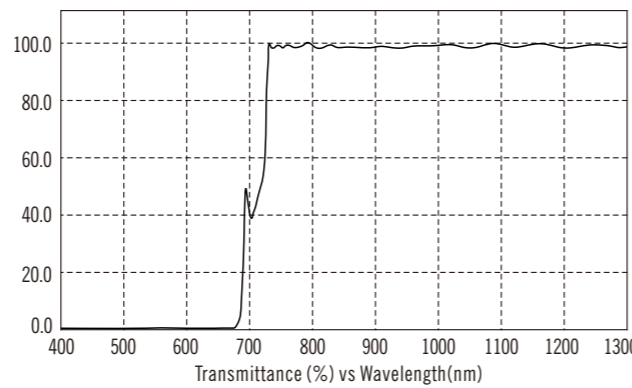

HR@400-680nm&HT@750-1300nm AOI=45°

DIELECTRIC COATING- HR COATING AND PR COATING

A dielectric coating consisting of alternating layers of quarter-wave film of a higher refractive index and lower refractive index than the substrate. Such coatings can be made very specific to a reflected wavelength or, by varying the layers' thicknesses or film indexes, spread over a wide wavelength interval including high reflection coating (HR) and partial reflective coating (PR).

Illuminant: WHITE
 Medium: AIR
 Substrate: GLASS
 Exit: GLASS
 Detector: IDEAL
 Angle: 0.0(deg)
 Reference: 1100.0(nm)
 Polarization: Ave
 First Surface: Front

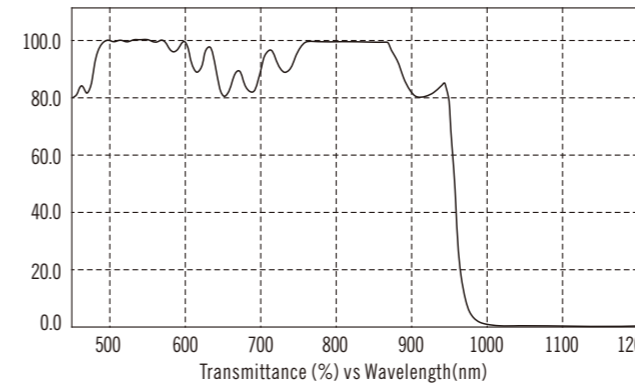

HR@1064nm&HT@532nm&808nm AOI=0°

Illuminant: WHITE
 Medium: AIR
 Substrate: GLASS
 Exit: GLASS
 Detector: IDEAL
 Angle: 45.0(deg)
 Reference: 630.0(nm)
 Polarization: Ave
 First Surface: Front
 X:406.3 Y:70.7

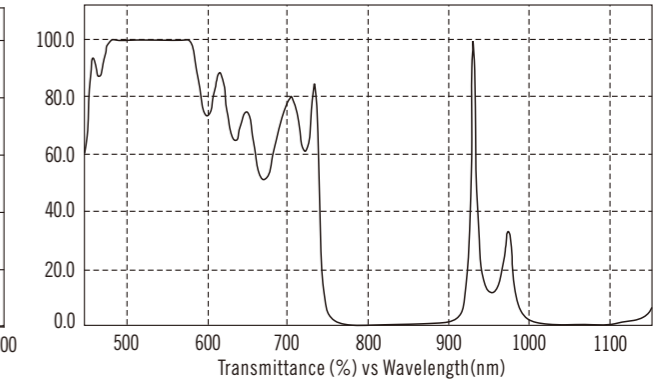

HR@1064nm&808nm&HT@532nm AOI=45°

Illuminant: WHITE
 Medium: AIR
 Substrate: GLASS
 Exit: GLASS
 Detector: IDEAL
 Angle: 0.0(deg)
 Reference: 1100.0(nm)
 Polarization: Ave
 First Surface: Front

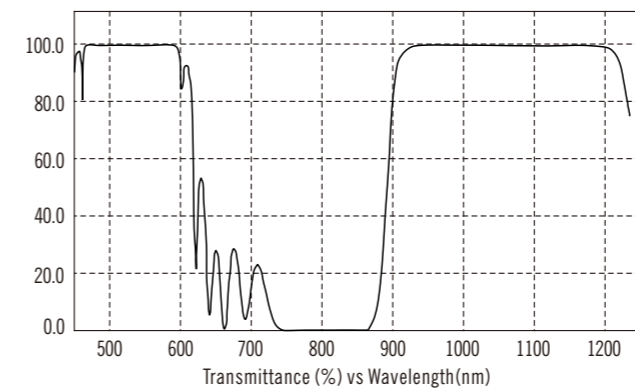

HR@1064nm&532nm&HT@808nm AOI=0°

Illuminant: WHITE
 Medium: AIR
 Substrate: JGS1
 Exit: JGS1
 Detector: IDEAL
 Angle: 13.0(deg)
 Reference: 1900(nm)
 Polarization: Ave
 First Surface: Front

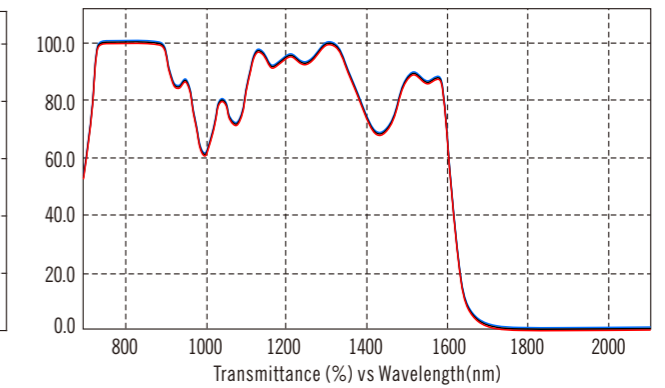

HR@1800-2000nm&HT@785-815nm

POLARIZATION BEAMSPLITTER COATING

An optical device for dividing a beam into two or more separate beams. A simple beamsplitter may be a very thin sheet of glass inserted in the beam at an angle to divert a portion of the beam in a different direction. A more sophisticated type consists of two right-angle prisms cemented together at their hypotenuse faces. The cemented face of one prism is coated, before cementing, with a metallic or dielectric layer having the desired reflecting properties, both in the percentage of reflection and the desired color.

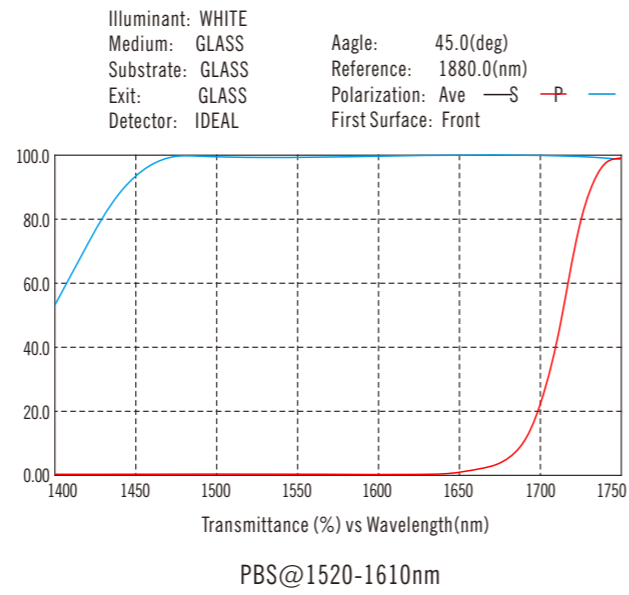
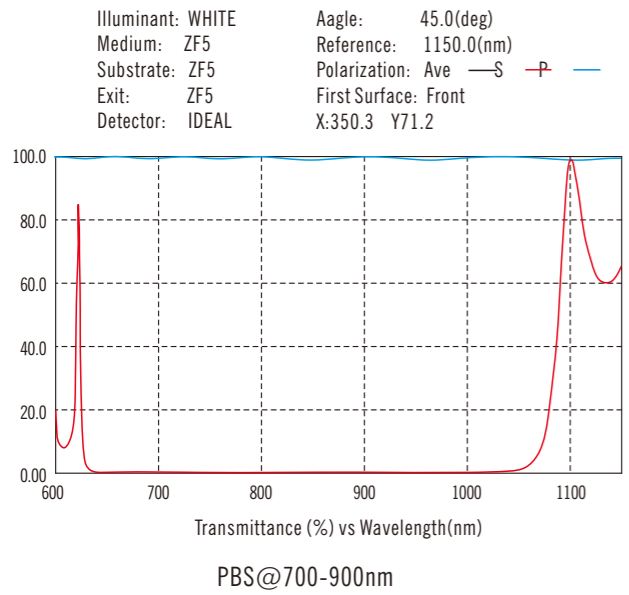
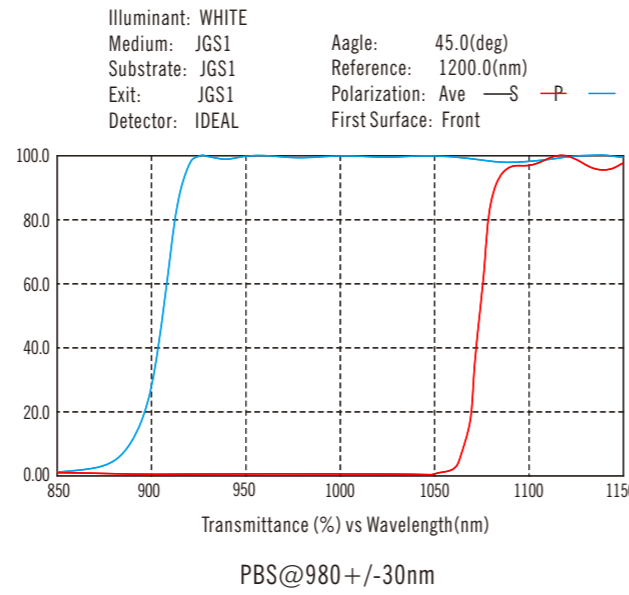
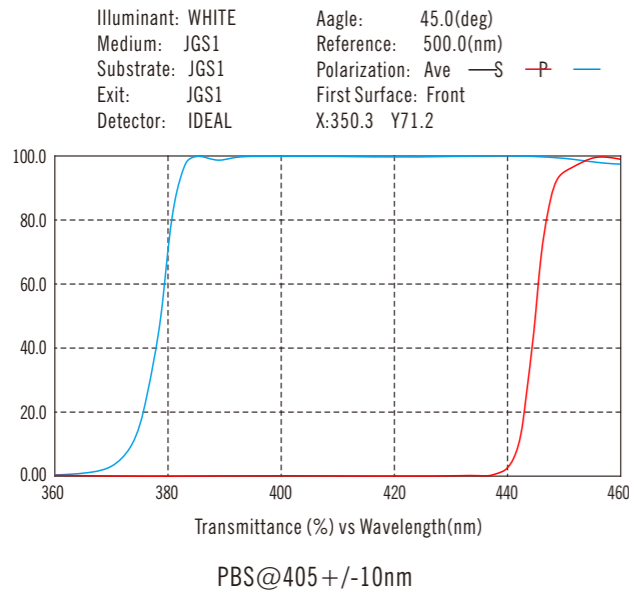

MIRROR--METAL COATING

A thin layer of metal deposited on the surface of a substrate. The film may serve as a reflector, beamsplitter, neutral density filter or electromagnetic interference filter. The most common metal coating as for mirror is Al, Ag, Au, Cr, etc.

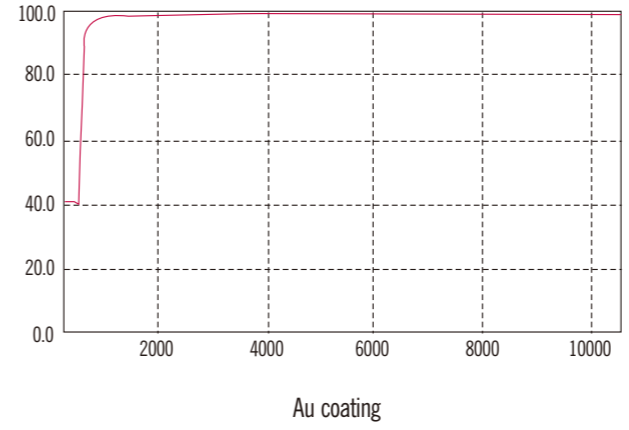
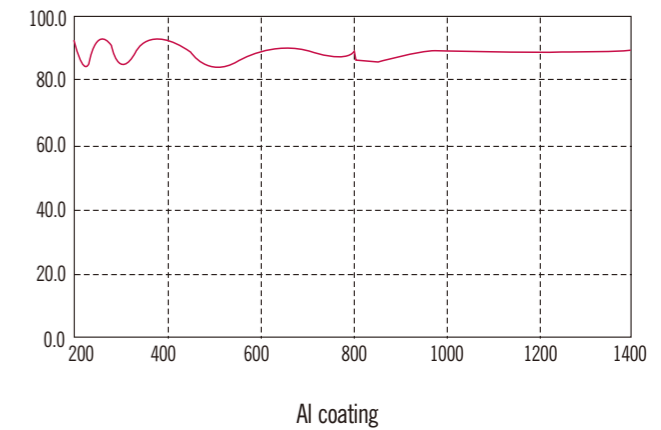
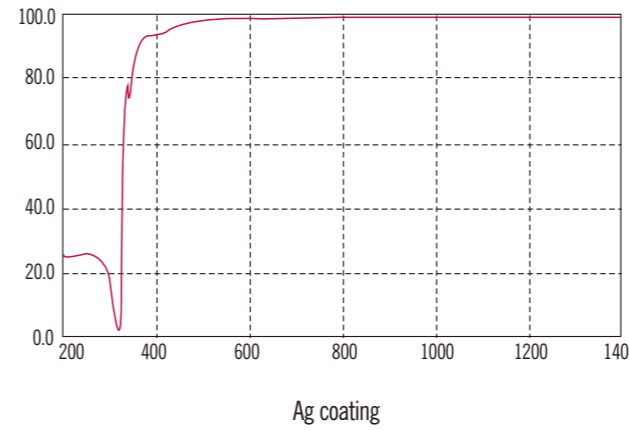

BIREFRIGENT CRYSTAL

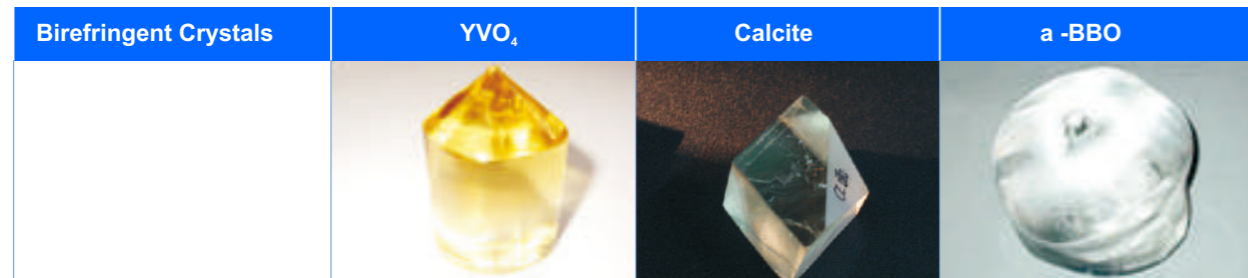

Physical and Optical Properties

Property	YVO ₄	Calcite	a -BBO
Transparency Range	500~4000nm	350~2300nm	190~3500nm
Crystal Structure	Trigonal, Space Group R3c	Trigonal, Space Group R3c	Trigonal, Space Group R3c
Crystal Class	Positive Uniaxial	Positive Uniaxial	Negative Uniaxial
Crystal Cell	a=b=7.12Å, c=6.29Å	a=b=4.621Å, c=3.053Å	a=b=12.532 Å, c=12.717 Å
Density	4.22g/cm ³	2.7g/cm ³	3.85g/cm ³
Hygroscopic Susceptibility	Low	Low	Low
Mohs Hardness	5	3	4.5
Thermal Expansion Coefficients	a _t =4.43x10 ⁻⁶ /k a _c =11.37x10 ⁻⁶ /k	a _t =24.39x10 ⁻⁶ /k a _c =5.68x10 ⁻⁶ /k	a _t =4 x 10 ⁻⁶ /k a _c =36 x 10 ⁻⁶ /k
Optical Homogeneity	10 ⁻⁶ /cm	10 ⁻⁶ /cm	10 ⁻⁶ /cm
Absorption Coefficient	0.05%/cm-1 @ 1064 nm	0.07 @ 200nm 0.02 @ 500nm	0.05%/cm-1 @ 1064 nm
Refractive Index, Birefringence(Δn=ne-no) Walk-Off Angle @ 45°(ρ)	n _o =2.2154, n _e =1.9929 Δn=0.2251 ρ=6.042° @ 633nm	n _o =1.4852, n _e =1.6557 Δn=0.1705 ρ=6.20° @ 633nm	n _o =1.67056, n _e =1.54831 Δn=0.1222 ρ=4.345° @ 532nm

Capabilities

Capability	YVO ₄	Calcite	a -BBO
Diameter	Max. 30~40mm	Max. 150mm	Max. 40~50mm
Length	Max. 25~35mm	Max. 100mm	Max. 25~35mm
Surface Quality	Better than 20/10 Scratch/Dig Per MIL-0-13830A		
Beam Deviation	< 10 arc seconds		
Optical Axis Orientation	+/-0.2°		
Flatness	< λ/8 @633nm		
Transmission Wavefront Distortion	< λ/4 @633nm		
Coating	Upon Specification		

BIREFRIGENT CRYSTAL

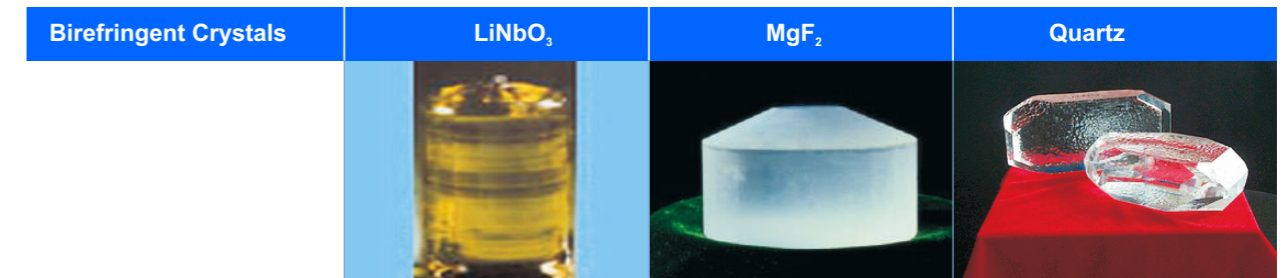

Physical and Optical Properties

Property	LiNbO ₃	MgF ₂	Quartz
Transparency Range	420~5200nm	120~8500nm	200~2300nm
Crystal Structure	Trigonal, Space Group R3c	Trigonal, Space Group R3c	Trigonal, Space Group R3c
Crystal Class	Positive Uniaxial	Positive Uniaxial	Negative Uniaxial
Crystal Cell	a=b=0.515Å, c=13.863 Å	a=b=4.621 Å, c=3.053 Å	
Density	4.64g/cm ³	3.18g/cm ³	2.65g/cm ³
Hygroscopic Susceptibility	Low	Low	Low
Mohs Hardness	5	6	7
Thermal Expansion Coefficients	a _t =2.0x10 ⁻⁶ /k @ 25°C c _t =2.2x10 ⁻⁶ /k @ 25°C	a _t =6.23-9.25x10 ⁻⁶ /k a _c =10.86-14.54x10 ⁻⁶ /k	a _t =6.2x10 ⁻⁶ /k a _c =10.7x10 ⁻⁶ /k
Optical Homogeneity	5 x 10 ⁻⁶ /cm	10 ⁻⁶ /cm	10 ⁻⁶ /cm
Absorption Coefficient	0.1%/cm @ 1064 nm	0.07 at 0.2 μm; 0.02 at 5.0 μm	0.1%/cm @ 1064 nm
Refractive Index, Birefringence(Δn=ne-no) Walk-Off Angle @ 45°(ρ)	n _o =2.20263, n _e =2.28629 Δn=0.08366 ρ=2.135° @ 633nm	N _o =1.38876, n _e =1.37698 Δn=0.01178 ρ=0.488° @ 633nm	n _o =1.55170, n _e =1.54265 Δn=0.00905 ρ=0.335° @ 633nm

Capabilities

Capability	LiNbO ₃	MgF ₂	Quartz
Diameter	Max. 30~40mm	Max. 50mm	Max. 100mm
Length	Max. 25~35mm	Max. 100mm	Max. 100mm
Surface Quality	Better than 20/10 Scratch/Dig Per MIL-0-13830A		
Beam Deviation	< 10 arc seconds		
Optical Axis Orientation	+/-0.2°		
Flatness	< λ/8 @633nm		
Transmission Wavefront Distortion	< λ/4 @633nm		
Coating	Upon Specification		

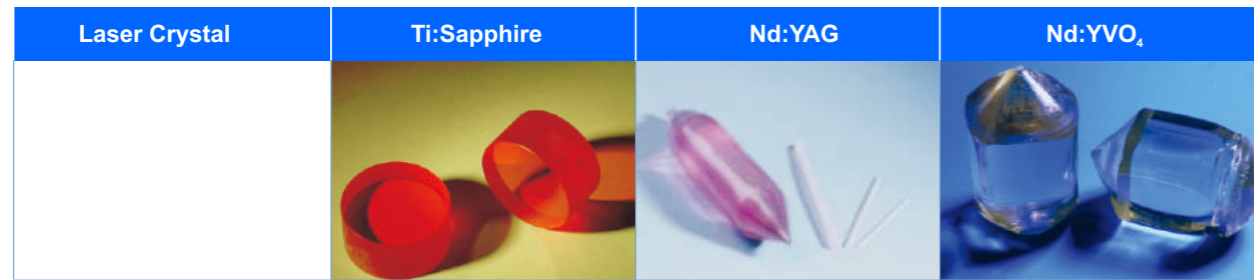

Physical and Optical Properties

Property	Ti:Sapphire	Nd:YAG	Nd:YVO ₄
Chemical Formula	Ti ₃ + Al ₂ O ₃	Nd: Y ₃ Al ₅ O ₁₂	Nd:YVO ₄
Crystal Structure	Hexagonal	Cubic	Zircon Tetragonal, Space Group D4h
Melting Point	2050 ° C	1970 ° C	
Density	3.98 g/cm ³	4.56 g/cm ³	4.22 g/cm ³
Mohs Hardness	9	8.5	5
Thermal Conductivity Coefficient	0.11 cal/(°C x sec x cm)	14 W/m /K @20° C 10.5 W /m /K @100° C	C: 5.23 W/m/K ^C: 5.10 W/m/K
Thermal Expansion Coefficient		7.8 x 10 ⁻⁶ /K [111], 0 - 250° C	a _z = 4.43x10 ⁻⁶ /K a _x = 11.37x10 ⁻⁶ /K
Lasing Wavelength	660~1050 nm (795nm)	1064nm	914nm, 1064nm, 1342nm
Absorption Range	400~600 nm (488nm)	lamp pump	808nm
Lattice Constants	a=4.748, c=12.957	12.01	a=b=7.12, c=6.29
Fluorescence Lifetime	3.2 μ sec (T = 300 K)	230msec	90 msec (about 50 m s for 2 atm% Nd doped) @ 808nm
Absorption Coefficient	1.0~7.5cm ⁻¹ @490nm	7.1 cm ⁻¹	31.4 cm ⁻¹ @ 808 nm
Refractive Index	1.76 @ 800nm	1.82 @1064nm	n _o = 1.9573, n _e = 2.1652@1064nm
Polarized Emission	Unpolarized	Unpolarized	Parallel to Optic Axis (C-axis)

Capabilities

Property	Ti:Sapphire	Nd:YAG	Nd:YVO ₄
Concentration	0.06~0.5 wt% Ti dopant	0.5~1.2 atm% Nd dopant (10% tolerance)	0.2~3 atm% Nd dopant (10% tolerance)
Figure of Merit	100~300		
Aperature	2~50mm	3~14mm	1~20mm
Path Length	2~130mm	1~60mm	0.02~20mm
End Configuration	Flat/Flat or Brewster/Brewster Ends or Specified		

Laser Crystal	Ti:Sapphire	Nd:YAG	Nd:YVO ₄
Orientation	Optical Axis C Normal to Rod Axis	<111> Crystalline Direction (+/-0.5° C)	a-cut Crystalline Direction (+/-0.5° C)
Parallelism	< 10 arc seconds		
Surface Quality	Better than 60/40 Scratch/Dig per MIL-0-13830A	Better than 20/10 Scratch/Dig per MIL-0-1380A	Better than 20/10 Scratch/Dig per MIL-0-1380A
Surface Flatness	< λ /10 @633nm	< λ /10 @ 632.8nm	< λ /10 @ 632.8nm
Wavefront Distortion	< λ /4 per inch @ 633 nm	<λ /10 @ 632.8nm for 3~7mm <λ /8 per inch @ 632.8nm for >=7mm	< λ /8 @ 633nm
Perpendicularity	< 5 arc minutes	< 5 arc minutes	< 5 arc minutes
Clear Aperture	Central 90%	Central 95%	Central 95%
Chamfer	0.15x44°	0.15x45°	0.15x45°
Damage Threshold	Over 15J/cm ² (Rods without Coating) over 700MW/cm ² (Coating)	Over 15J/cm ² (Rods without Coating) Over 700MW/cm ² (Coating)	Over 15J/cm ² (Rods without Coating) Over 700MW/cm ² (Coating)
Coatings	AR@700~1100nm	a) AR@1064nm,R<0.1% b) AR@1064nm,R<0.1%; HT@808nm,T>95%; c) HR@1064nm,R<99.8%; HT@808nm,T>95%; d) HR@1064nm,R<99.8%; HT@808nm,T>95%; HR@532nm,R>99%	a) AR@1064nm,R<0.1% b) AR@1064nm,R<0.1%; HT@808nm,T>95%; c) HR@1064nm,R<99.8%; HT@808nm,T>95%; d) HR@1064nm,R<99.8%; HT@808nm,T>95%; HR@532nm,R>99%



Physical and Optical Properties

Crystal Structure	Trigonal, Space Group R3c	Orthorhombic, Point Group mm ²	Orthorhombic, Point Group mm ²	Trigonal, Space Group R3c
Transparency Range	189–3500 nm	350nm~4500nm	160–2600 nm	420–5200 nm
Cell Parameters	A=b=12.532Å C=12.717Å	A=6.404Å B=10.616Å C=12.814Å	A=8.44731Å B=7.3788Å C=5.1395Å	a = 0.515Å c = 13.863Å
Melting Point	1095 +/-5 ° C	1172 ° C Incongruent	834 ° C	1255 +/-5 ° C
Curie point	925 +/-5 ° C	936 ° C		1140 +/-5 ° C
Optical Homogeneity	$\Delta n \approx 10^{-6} / \text{cm}$	$\Delta n \approx 10^{-6} / \text{cm}$	$\Delta n \approx 10^{-6} / \text{cm}$	$\Delta n \approx 5 \times 10^{-5} / \text{cm}$
Mohs Hardness	4.5	5	6	5
Density	3.85 g/cm ³	3.01 g/cm ³	2.47g/cm ³	4.64 g/cm ³
Thermal Conductivity	$\wedge c, 0.012 \text{ W/cm/K}$ $ c, 0.016 \text{ W/m/K}$	0.03 W/cm/K	0.035 W/cm/K	0.046 W/cm/K
Phase-matchable SHG Range	205nm~1750nm	1000–2000nm	800–2000nm	1100~3000nm
Absorption Coefficient	< 0.1%/cm @ 1064nm	< 1%/cm @1064nm and 532 nm	< =1%/cm @ 1064nm	<0.1%/cm @ 1064 nm
NLO coefficients	$d_{31} = 2.2\text{pm/V}$ $d_{31} = 0.08\text{pm/V}$ $d_{22} = 2.2\text{pm/V}$	$d_{31} = 1.95\text{pm/V}$ $d_{32} = 3.90\text{pm/V}$ $d_{33} = 15.3\text{pm/V}$ $d_{24} = 3.90\text{pm/V}$ $d_{15} = 1.95\text{pm/V}$	$d_{21} = 0.67\text{pm/V}$ $d_{22} = 0.04\text{pm/V}$ $d_{23} = 0.85\text{pm/V}$ $d_{34} = 0.85\text{pm/V}$ $d_{16} = 0.67\text{pm/V}$	$d_{21} = d_{22} = d_{15} = 2.6\text{pm/V}$ $d_{31} = d_{32} = d_{33} = 4.6\text{pm/V}$ $d_{33} = 25.6\text{pm/V}$
Damage Threshold @ 1064 nm	12.9J/cm ² ; 9.9GW/cm ²	6.0J/cm ² ; 4.6GW/cm ²	24.6J/cm ² ; 18.9GW/cm ²	200 MW/cm ²
Refractive Indices@ 1064nm@532nm	$n_x = 1.5425$ $n_y = 1.6551$ $n_z = 1.5555$ $n_o = 1.6749$	$n_x = 1.73991$ $n_y = 1.74802$ $n_z = 1.82956$ $n_x = 1.77903$ $n_y = 1.79002$ $n_z = 1.88628$	$n_x = 1.56447$ $n_y = 1.59050$ $n_z = 1.60538$ $n_x = 1.57842$ $n_y = 1.60650$ $n_z = 1.62154$	$n_o = 2.23216$ $n_y = 2.15600$ $n_z = 2.32309$ $n_x = 2.23415$

Typical Specification and Capabilities

NLO Crystal	BBO	KTP	LBO	LiNbO ₃
Angle Tolerance	$\Delta \theta < \pm 0.5^\circ$; $\Delta \phi < \pm 0.5^\circ$			
Dimension Tolerance	(W ± 0.1mm) x (H ± 0.1mm) x (L + 0.2mm/-0.1mm)	(W ± 0.1mm) x (H ± 0.1mm) x (L + 0.2mm/-0.1mm)	(W ± 0.1mm) x (H ± 0.2mm) x (L + 0.2mm/-0.2mm)	(W ± 0.1mm) x (H ± 0.2mm) x (L + 0.2mm/-0.2mm)
Flatness	< $\lambda / 8$ @ 633nm	< $\lambda / 8$ @ 633nm	< $\lambda / 4$ @ 632.8nm	< $\lambda / 8$ @ 633nm
Scratch/Dig Code	Better than 10/5 Scratch/Dig per MIL-O-13830A			
Parallelism	< 20 arc seconds			
Perpendicularity	< 5 arc minutes	< 5 arc minutes	< 30 arc minutes	< 5 arc minutes
Wavefront Distortion	< $\lambda / 8$ @ 633nm	< $\lambda / 8$ @ 633nm	< $\lambda / 4$ @ 632nm	< $\lambda / 8$ @ 632nm
Clear Aperture	> 90% Central Area	> 90% Central Area	> 80% Central Area	> 90% Central Area
Aperture	1x1~12x12mm	1x1~10x10mm	2~10mm	1~50mm
Length	0.02~25mm	0.05~20mm	0.3~20mm	0.3~20mm
Phase Matching Type	Type I or Type II	Type II	Type I or Type II	Type I or Type II
End Configuration	Flat or Brewster or Specified	Flat or Brewster or Specified	Flat, Spherical, Parallel and Wedged	Flat, Spherical, Parallel and Wedged
Typical Coating	Antireflective coating	Antireflective coating Highreflective coating	Antireflective coating	Antireflective coating

Cr 4+ :YAG



Physical Properties

Chemical Formula	Cr ⁴⁺ : Y ₃ Al ₅ O ₁₂
Crystal Structure	Cubic Garnet
Recovery Time	8.5 μs
Hardness Mohs	8.5
Density	4.56g/cm ³
Orientation	[100] +/- 10°
Thermal Conductivity	12.13W/m/K
Refractive Index	1.82 @ 1064nm

Optical Properties

Base State Absorption Cross Section	$\sigma_{s1} = 4.3 \times 10^{-18} \text{ cm}^2$
Emission State Absorption Cross Section	$\sigma_{s2} = 8.2 \times 10^{-19} \text{ cm}^2$
Fluorescence Lifetime	3.4 μs

Capabilities

Cr ⁴⁺ Dopant Concentration	0.5 mol% ~ 3 mol%
Aperture	2x2 ~ 14x14mm
Initial transmission	10% ~ 99%

Typical Specification and Tolerance

Dimension Tolerance	(W ± 0.1mm) x (H ± 0.1mm) x (L + 0.2mm/-0.1mm)
Flatness	< λ/8 @ 633nm
Scratch/Dig	Better than 10/5 Scratch/Dig per MIL-O-13830A
Parallelism	< 20 arc seconds
Perpendicularity	< 5 arc minutes
Wavefront Distortion	Less than λ/8 @ 633nm
Clear Aperture	> 90% Central Area
Coating	Anti-reflective

Terbium Gallium Garnet (TGG) is the right crystal material for Farady devices (Rotator and Isolator). The Farady rotator is made up of a TGG rod contained in a special designed magnet. The polarization of a light beam passing through the rotator makes rotation. The direction of rotation is only dependent on the direction of the magnetic field and not on the direction of propagation of the light beam. The optical isolator consists of a 45 degree rotator set between two suitably arrayed polarizers which allow a light beam to pass through in one direction only. With a combination of excellent properties, such as large Verdet constant, low light loss, high thermal conductance and high light damage threshold, TGG is the unique material for Farady devices. It is widely used for YAG lasers and Ti:sapphire tunable lasers, ring lasers, etc.

Physical Properties

Crystal	Terbium Gallium Garnet (Tb ₃ Ga ₅ O ₁₂)
Orientation	[111] Within 5 Degrees
Wavefront Distortion (Per Inch of Rod Length)	λ/8
Extinction Ratio	30 dB over 2/3 Clear Aperture
Diameter Tolerance	+0.000" / -0.002"
Length Tolerance	+0.010 / -0.010"
Chamfer	0.005" ± 0.003" @ 45° ± 5°
Flatness	λ / 10 wave @ 633 nm
Parallelism	< 1 minutes of arc
Perpendicularity	< 10 minutes of arc
Surface Quality	10/5 Scratch/Dig per MIL-O-13830A
Reflectivity	< 0.25% @ 1064 nm
Thermal Conductivity	7.4 W cm ⁻¹ K ⁻¹
Refractive Index	1.95 @ 1064nm

OPTICAL CRYSTAL

CaF₂

CaF₂ is a crystal, which has good transmission from 170 nm to 7800 nm. It's slightly soluble in water and susceptible to thermal shock. CaF₂ is commonly used in IR components such as windows, Lenses and prisms.

- Transmission Range: 170 nm~7800 nm
- Thermal Expansion Coefficient: 18.85X10⁻⁶/K
- Density: 3.18 g/cm³

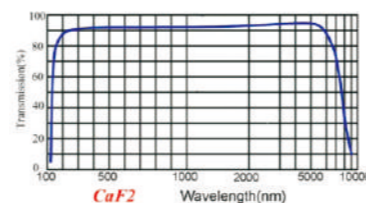

Sapphire

Sapphire is a single crystal aluminum oxide (Al₂O₃). It is one of the hardest materials. Sapphire has good transmission characteristics over the visible, and near IR spectrum. It exhibits high mechanical strength, chemical resistance, thermal conductivity and thermal stability. It is often used as window materials in specific field such as space technology where scratch or high temperature resistance is required.

Physical Properties

Crystal Symmetry	Hexagonal System
Lattice Constant	a = 4.75 ; c = 12.97
Transparence Range	0.18~4.5 μ m
Density	3.98 g/cm ³
Mohs Hardness	9
Melting Point	2030 °C
Thermal Conductivity	0.04 W/m/K
Expansion Coefficient	8.4 x 10 ⁻⁶ /K
Refractive Index	1.755

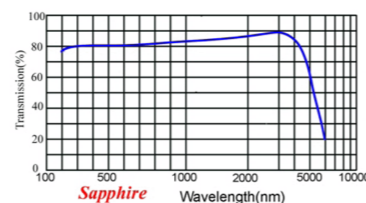

Silicon(si) Crystal

Silicon(Si) is commonly used as a substrate material for infrared reflectors and windows in the 1.5 μ m-8 μ m region. The strong absorption band at 9 μ m makes it unsuitable for CO₂ laser transmission applications but it is frequently used for laser mirrors because of its high thermal conductivity and low density. Silicon is also a useful transmitter in 20 μ m range.

Physical Properties

Material Type	CZ FZ; N or P
Crystal Direction	{100} {111}
Resistivity(Ohm/cm)	0.003-50
Thermal conductivity(J/K . M . S)	163.3@273K
Density(g/cm ³)	2.33g/cm ³ at 20 °C
Melting point	1410 °C
Boiling point	3265 °C
Knoop Hardness(kg/mm ²)	1150
Transparency Range	1000nm-10000nm 30000nm-300000nm

OPTICAL GLASS

Dayoptics has capability in manufacturing various optical components with a wide variety of optical materials. Selecting a optical material is important since each material has different optical characteristics, such as transmission versus wavelength, index of refracton, thermal, mechanical and chemical characteristics.

The index of refraction and Abbe Number of a glass are typically used by designers as degrees of freedom when designing systems. Dayoptics has a program that combines the foundation data of a wide variety of optical materials. It is easy for us to find the right materials for your application.

Many glass manufacturers offer the same material characteristics under different trade names. Based on availability,we reserve the right to substitute an equivalent glass in our production runs.

Herewith, the most common materials Dayoptics used:

Materials	Refractive Index (nd)	Abbe Number (Vd)	Density (g/cm ³)	Transmission Range (um)	Thermal Expansion Coefficient (10 ⁻⁶ /K)
BK7	1.517	64.2	2.52	0.33-2.1	7.5
SF5	1.673	32.17	4.08	0.33-2.5	8.2
SF11	1.785	25.76	4.87	0.37-2.5	6.8
Fused Silica	1.458	67.82	2.2	0.185-2.5	0.54
Prexy	1.474	65.38	2.23	0.23-2.7	3.25
CaF2	1.434	94.99	3.18	0.17-7.8	18.85
Sapphire	1.768	72.24	3.99	0.18-4.5	5.8

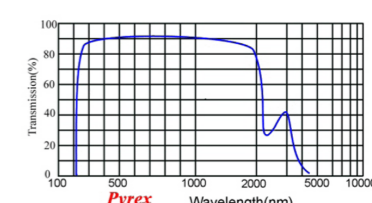
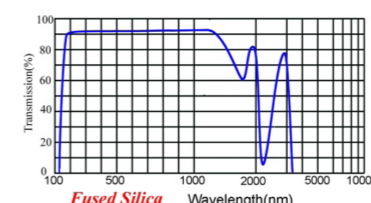
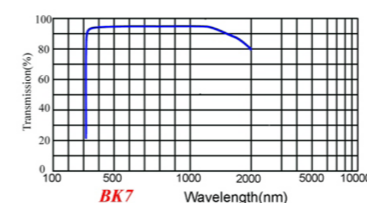

For the Schott material in this catalogue , we use Chinese equivalent material instead

Plano product Capability:

Attribute	Commercial	High Precision
End- faces Configuration	Flat	Flat
Dimension Tolerance	±0.1mm	±0.01mm
Surface Quality	40-20 scratch and dig	10-5 scratch and dig
Flatness	λ /4	λ /10
Parallelism	20 "	2 "
Perpendicularity	15 '	5 '

Lens Spocification :

Diarmeter size	5-50mm
Shape	Plano-convex, Double-convex, Plano-concave&Double-concave
Surface Figure: Power(N)	≤3
Irregularity(Δ,N)	≤0.5
Centration	Z>0.15:C≤3 Z>0.1-0.15:C≤30 Z<0.1:No centration
$(Z = \frac{D1 \pm D2}{R1 \pm R2})$	Double-convex and Double-concave lens: "+", Meniscus lens "-", Plano-convex and Plano-concave: R=∞)
Surface quality	40-20 scratch and dig, 5 ≤ φ ≤ 22mm 60-40 scratch and dig, 22 ≤ φ ≤ 50mm

OPTICAL GLASS

n_d	V_d	CDGM	SCHOTT	OHARA	HOYA	SUMITA	HIKARI
1.470	66.83	H-QK1	FK1	FSL1	FC1		
1.487	70.04	H-QK3					
1.487	70.44	H-QK3L	N-FK5	S-FSL5	FC5		E-FK5
1.500	62.07	K1	K11				
1.500	66.02	H-K2	BK4	BSL4	BSC4		
1.505	64.72	H-K3	BK5				
1.508	61.05	K4A	ZKN7	ZSL7	ZNC7		ZK7
1.510	63.36	H-K5	BK1	BSL1	BSC1		BK1
1.511	60.46	H-K6	K7	NSL7	C7		K7
1.515	60.63	H-K7					
1.516	56.79	K8		NSL2	C2		K2
1.517	64.2	H-K9L	N-BK7	S-BSL7	BSC7		E-BK7
1.517		H-UK9L	UBK7				
1.518	58.95	H-K10		S-NSL3	E-C3		E-K3
1.526	60.61	H-K11	BALK1	NSL21	BACL1		
1.534	55.47	H-K12	ZK5	ZSL5	ZNC5		ZK5
1.519	61.69	H-K16			BACL3		BALK3
1.522	59.48	H-K50	N-K5	S-NSL5	C5		E-K5
1.523	58.64	H-K51	B270	NSL51	C12		KN1
1.530	60.47	H-BaK1					
1.540	59.72	H-BaK2	N-BAK2	S-BAL12	BAC2		E-BaK2
1.547	62.78	H-BaK3		BAL21			PSK1
1.552	63.36	H-BaK4	N-PSK3	BAL23	PCD3		PSK3
1.561	58.34	BaK5					
1.564	60.76	H-BaK6	N-SK11	S-BAL41	BACD11		E-SK11
1.569	56.04	H-BaK7	N-BAK4	S-BAL14	BAC4		E-BAK4
1.573	57.49	H-BaK8	N-BAK1	S-BAL11	BAC1		E-BAK1
1.574	56.45	BaK9	BAK6	BAL16	BAC6		
1.560	61.21	BaK11	SK20	BAL50			SK20
1.569	62.93	H-ZK1	PSK2	BAL22	PCD2		PSK2
1.583	59.46	H-ZK2	SK12	S-BAL42	BACD12		SK12
1.589	61.25	H-ZK3	N-SK5	S-BAL35	BACD5		E-SK5
1.609	58.86	H-ZK4	SK3	BSM3	BACD3		BSM3
1.611	55.77	ZK5	SK8	BSM8	BACD8		
1.613	58.58	H-ZK6	N-SK4	S-BSM4	BACD4		E-SK4
1.613	60.58	H-ZK7					
1.614	55.12	ZK8	SK9	BSM9	BACD9		SK9
1.620	60.34	H-ZK9	N-SK16	S-BSM16	BACD16		E-SK16
1.623	56.71	H-ZK10	N-SK10	S-BSM10	E-BACD10		E-SK10
1.639	55.45	H-ZK11	N-SK19	S-BSM18	BACD18		E-SK18
1.603	60.6	H-ZK14	N-SK14	S-BSM14	BACD14		E-SK14
1.607	59.46	H-ZK15	SK7	BSM7	BACD7		SK7
1.614	56.4	H-ZK19	SK6	BSM6	BACD6		SK6
1.617	53.91	H-ZK20	SSK1	BSM21	BACED1		SSK1
1.623	58.12	H-ZK21	N-SK15	S-BSM15	BACD15		E-SK15
1.607	56.65	H-ZK50	SK2	BSM2	BACD2		E-SK2
1.618	55.14	ZK51	SSK4	BSM24	BACED4		SSK4

COLOR GLASS

Chinese color glass	Former USSR	SCHOTT	HOYA	Chinese color glass	Former USSR	SCHOTT	HOYA
ZIB220			UV-22	QB26		BG18	
ZIB240		WG230		QB29		BG25	B-380
ZIB260	Б C12			LB1	3C1	VG9	
ZIB280	Б C3	WG280	UV-28	LB2	3C2	VG11	
ZIB300	Б C4	WG295	UV-30	LB3	3C3		
ZIB320	Б C5	WG320	UV-32	LB4	3C6		
ZIB340	Б C10	WG345	UV-34	LB6	3C8		
ZIB360	Б C7	WG360	UV-36	LB7	Ж3C1	VB8	G-533
ZIB380	Б C8	GG375	L-38	LB8	Ж3C4		
JB400	Ж C4	GG400	L-40	LB9	Ж3C5	VB10	
JB420	Ж C11	GG420	L-42	LB10	Ж3C6		G-550
JB450	Ж C12	GG455	Y-44	LB11	Ж3C9		
JB470	Ж C16	GG475	Y-46	LB12	Ж3C10		
JB490	Ж C17	GG495	Y-48	LB13	Ж3C12		G-545
JB510	Ж C18	GG515	Y-50	LB14	Ж3C13		
CB535	OC11	GG530	O-54	LB15	Ж3C17		
CB550	OC12	GG550		LB16	Ж3C18		
CB565	OC13	GG570	O-56	LB17		VG5	
CB580	OC14	GG590	O-58	LB18		VG6	
HB600	KC10		R-60	LB19			
HB610	KC11	RG610		JB1	Ж C3	GG19	
HB630	KC13	RG630	R-62	JB9		GG10	
HB640	KC14	RG645	R-64	CB1	OC5		
HB650	KC15		R-66	CB2	OC6		
HB670	KC17	RG665		HB1	II C5		
HB685	KC18		R-68	HB3	II C8	RG6	
HB700	KC19	RG695	R-70	HB5	II C13		
HB720		RG715	R-72	HB6	II C2		
HWB760			IR-76	HWB1	I1 KC1		RM-86
HWB780		RG780		HWB3	I1 KC2	RG7	RM-90
HWB800			IR-80	HWB4	I1 KC3		
HWB830		RG830	IR-83	FB1	TC1		
HWB850			IR-85	FB3	TC3		
HWB900				GRB1	C3C14	KG2	HA-50
HWB930				GRB3	C3C16	KG30	HA-30
ZWB1	Y φ C2	UG11	U-340	PNB586	C7	BG20	V-10
ZWB2	Y φ C3	UG1	U-360	HOB445			HY1
ZWB3	Y φ C1	UG5	U-330	TB1			SL-1A
ZB1	φ C1		B-390	TB2			L-1B
ZB2	φ C6	BG3		SSB40		FG6	LB-40
ZB3	φ C7		B-370	SSB145		BG34	LB-145
QB1	CC1			SSB165		FG3	LB-165
QB2	CC2		B-410	SSB200			LB-200
QB3	CC4			SJB20		FG18	LA-20
QB4	CC5			SJB80		FG16	LA-80
QB5	CC8		B-440	SJB100			LA-100
QB9	C3C3			SJB130		FG15	LA-120
QB10	C3C5			SJB140			LA-140
QB11	C3C7	BG14		ZAB00	HC12	NG1	ND-0
QB12	C3C8		B-460	ZAB02	HC11	NG9	ND-03
QB13	C3C9			ZAB2	HC10	NG3	
Qb16	C3C15			ZAB5	HC3		